

FLOAT AND THERMOSTATIC STEAM TRAPS UniAdca FS 32H

DESCRIPTION

UniAdca FS 32H complete stainless steel, maintenance free sealed float and thermostatic (integral air vent) steam traps series are designed for all types of low and medium pressure steam heating and process equipment.

Typical applications include unit heaters, heat exchangers, driers, jacketed vessels and all the applications where continuous drainage is essential.

These traps fits the CX40 UniAdca connectors.

MAIN FEATURES

Modulating discharge.

Discharges condensate at steam temperature.

Unaffected by sudden or wide load and pressure changes.

Excellent air discharge (by thermostatic air vent)

OPTIONS: Equalizing plug, venting connection and drain plug (or blow-off valve on body).

USE : Saturated and superheated steam

AVAILABLE

MODELS : FS32H-4.5 - FS32H-10 - FS32H-14.

SIZES : DN1" - DN25.

DN11/2" – DN40 Duplex connectors only

According to the pipeline connector.

See IS 1.0910 and IS 1.0915

INSTALLATION : Always in a horizontal plane with the plug pointing downwards.

See IMI installation and maintenance instructions.

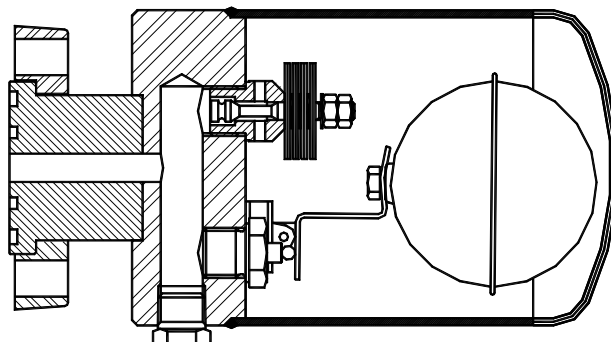

Materials:

AISI316 / 1.4401 throughout

Weight : 8,7 kgs

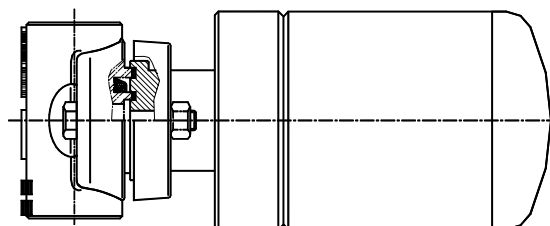

Steam trap plus pipe connector

See IS 1.0965 and IS 1.0970

PMA – Max.allowable pressure	40 bar	MAX. DIFFERENTIAL PRESSURE
TMA – Max.allowable temperature	400 °C	FS32H-4,5 : 4,5 bar
PMO – Max.operating pressure	14 bar	FS32H-10 : 10 bar
TMO – Max.operating temperature	235 °C	FS32H-14: 14 bar

How to order:

-Steam trap : FS 32H (Float and thermostatic steam trap).

-Pipe connector :

-CX40SS DN 1" or DN25 (Stainless steel pipe connector)

-CX402SS DN 1" or DN25 (Stainless steel duplex pipe connector)

-CX402SS DN 11/2" or DN 40 (Stainless steel duplex pipe connector)

-The complete set :

FS32HXSS DN 1" or DN25 (Stainless steel connector CX40SS DN 1"-DN25 plus FS32H steam trap)

FS32HX2SS DN 1" or DN25 (Stainless steel duplex connector CX402SS DN1"-DN25 plus two FS32H steam traps)

FS32HX2SS DN 11/2" or DN40 (Stainless steel duplex connector CX402SS DN 11/2"-DN40 plus two FS32H steam traps)

FLOW RATE CAPACITY IN Kgs/h														
MODEL	SIZE	DIFFERENTIAL PRESSURE (bar)												
		0,5	1	1,5	2	3	4,5	6	7	8	9	10	12	14
FS32H-4,5	1"	900	1250	1450	1700	2010	2400							
FS32H-10	1"	450	620	790	880	1100	1250	1500	1600	1700	1750	1800		
FS32H-14	1"	340	435	530	600	610	850	990	1100	1190	1240	1300	1350	1380

Remarks: duplex traps has twice the capacity.