

UNIADCA PIPELINE CONNECTORS PLUS STEAM TRAPS Dimensions and weights (Duplex design)

FS32X2S and FS32X2SS						
DIMENSIONS (mm)-Screwed					EN 1092-1 Flanges	
SIZE DN	B	C	E	WGT. Kgs	F	WGT. Kgs
25	394	197	90	7,5	160	10

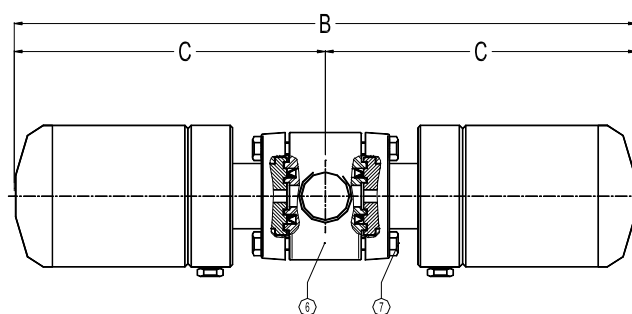

FS32HX2S and FS32HX2SS						
DIMENSIONS (mm)-Screwed					EN 1092-1 Flanges	
SIZE DN	B	C	E	WGT. Kgs	F	WGT. Kgs
25	522	261	142	17,5	160	20
40	534	267	142	19	230	24

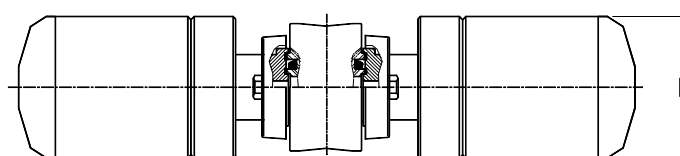

TS22X2S and TS22X2SS						
DIMENSIONS (mm)-Screwed					EN 1092-1 Flanges	
SIZE DN	A	B	C	WGT. Kgs	F	WGT. Kgs
25	80	120	60	2,9	160	5,5

