



## FLOAT AND THERMOSTATIC STEAM TRAPS FLT 22 S – Carbon steel / FLT 22 SS – Stainless steel

### DESCRIPTION

FLT 22 float and thermostatic (integral air vent) steam traps series are designed for all types of low and high pressure steam heating and process equipment.

Typical applications include unit heaters, heat exchangers, driers, jacketed vessels and all the applications where continuous drainage is essential.

Connections are female screwed or flanged.

### MAIN FEATURES

Modulating discharge.

Discharges condensate at steam temperature.

Unaffected by sudden or wide load and pressure changes.

Excellent air discharge (by thermostatic air vent).

USE: Saturated and superheated steam.

### AVAILABLE

MODELS: FLT 22S – Carbon steel

FLT22SS – Stainless steel

SIZES: DN 1 1/2" - 2" ; DN 40 – DN 50

CONNECTIONS: Female screwed

Flanged DIN or ANSI

INSTALLATION: Horizontal standard installation

from right to left (R-L).

Left to right (L-R) or vertical installation

top to bottom (V) on request

PMA – Max.allowable pressure 25 bar

TMA – Max.allowable temperature 300 °C

PMO – Max.operating pressure 21 bar

TMO – Max.operating temperature 250 °C

How to order:i.e. FLT22SS DN 50 DIN

### MAX. DIFFERENTIAL PRESSURE

FLT22S-4,5 : 4,5 bar

FLT22S-10 : 10 bar

FLT22S-14: 14 bar

FLT22S-21: 21 bar

Note: the same figures are valid for the FLT22SS

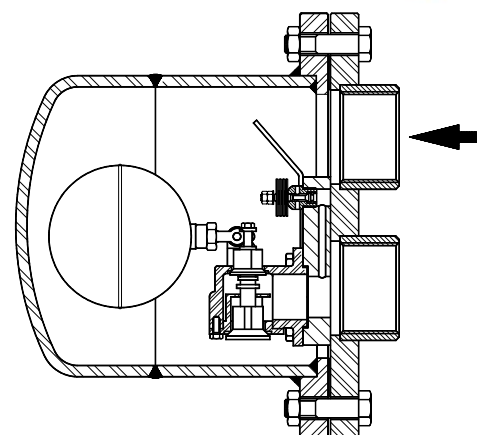

### CE MARKING (PED - European Directive 97/23/EC)

| PN 25       | Category      |
|-------------|---------------|
| DN40 - DN50 | 1 (CE Marked) |

### FLOW RATE CAPACITY IN Kgs/h

| MODEL      | SIZE      | DIFFERENTIAL PRESSURE (bar) |      |       |       |       |       |       |      |      |      |       |       |
|------------|-----------|-----------------------------|------|-------|-------|-------|-------|-------|------|------|------|-------|-------|
|            |           | 0,5                         | 0,7  | 1     | 1,5   | 2     | 4,5   | 7     | 10   | 12   | 14   | 16    | 21    |
| FLT22S-4,5 | 1 1/2"-40 | 2400                        | 2800 | 3400  | 3900  | 4500  | 7300  |       |      |      |      |       |       |
| FLT22S-10  | 1 1/2"-40 | 1500                        | 1750 | 2000  | 2600  | 3000  | 4000  | 5400  | 6200 |      |      |       |       |
| FLT22S-14  | 1 1/2"-40 | 950                         | 1100 | 1300  | 1600  | 1800  | 2600  | 3250  | 3900 | 4210 | 4950 |       |       |
| FLT22S-21  | 1 1/2"-40 | 950                         | 1100 | 1300  | 1600  | 1800  | 2600  | 3250  | 3900 | 4210 | 4950 | 5000  | 5600  |
| FLT22S-4,5 | 2"-50     | 7550                        | 9050 | 11000 | 14000 | 15500 | 22500 |       |      |      |      |       |       |
| FLT22S-10  | 2"-50     | 3900                        | 4450 | 5000  | 6100  | 7100  | 10000 | 13750 | 1600 |      |      |       |       |
| FLT22S-14  | 2"-50     | 1900                        | 2300 | 2700  | 3100  | 3600  | 5000  | 6900  | 8100 | 9000 | 9800 |       |       |
| FLT22S-21  | 2"-50     | 1900                        | 2300 | 2700  | 3100  | 3600  | 5000  | 6900  | 8100 | 9000 | 9800 | 10000 | 12050 |

Note: the same figures are valid for the FLT22SS

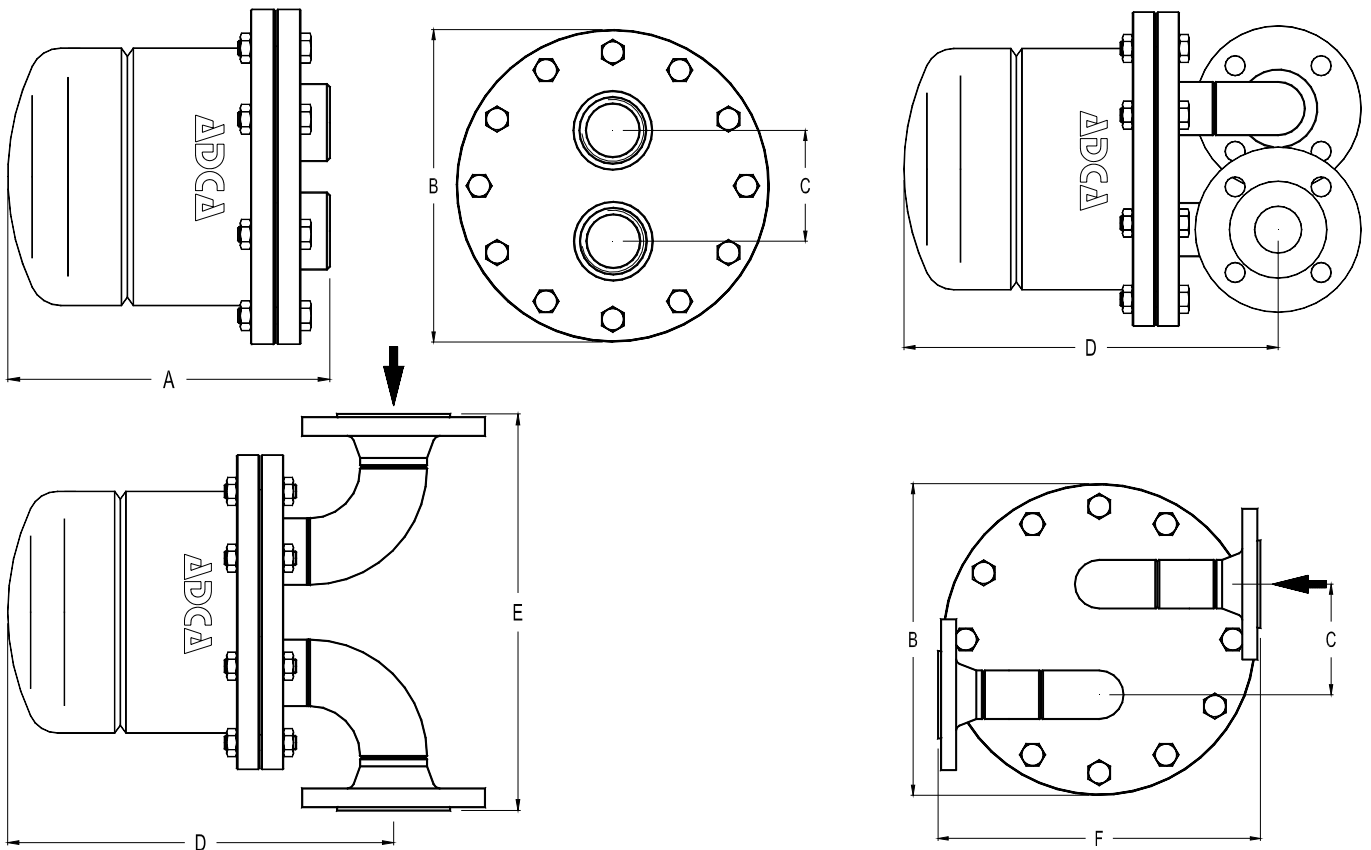

| DIMENSIONS (mm)-Screwed |     |     |     |          | DIN Flanges |     |     |          |
|-------------------------|-----|-----|-----|----------|-------------|-----|-----|----------|
| SIZE DN                 | A   | B   | C   | WGT. Kgs | D           | E   | F   | WGT. Kgs |
| 40                      | 290 | 310 | 110 | 41       | 355         | 320 | 320 | 43       |
| 50                      | 290 | 310 | 110 | 42       | 355         | 360 | 320 | 45       |

| MATERIALS |           |   |                                     |
|-----------|-----------|---|-------------------------------------|
| POS. Nr.  | DESIGN.   | MATERIAL FLT22S   | MATERIAL FLT22SS                    |
| 1         | Body      | P250GH / 1.0460 ; P235GH / 1.0305 ; S355J2G3 / 1.0570 ; S235JRG2/1.0038 | AISI316 / 1.4401 ; AISI304 / 1.4301 |
| 2         | Cover     | P235GH / 1.0305 ; P265GH / 1.0425 ; S355J2G3 / 1.0570                   | AISI316 / 1.4401 ; AISI304 / 1.4301 |
| 3         | *Gasket   | Graphite  | Graphite                            |
| 4         | *Seat     | CF8 / 1.4308  | CF8 / 1.4308                        |
| 5         | *Valve    | AISI420 / 1.4021  | AISI420 / 1.4021                    |
| 6         | *Lever    | AISI304 / 1.4301  | AISI304 / 1.4301                    |
| 7         | *Float    | AISI304 / 1.4301  | AISI304 / 1.4301                    |
| 8         | *Air vent | Stainless steel (Bimetalic)   | Stainless steel (Bimetalic)         |
| 9         | Bolts     | Steel 8.8   | St. Steel - A2                      |

\*Available spare parts.

