

BIMETALLIC STEAM TRAPS AND AIR ELIMINATORS BM 24 (DN40 – DN50)

DESCRIPTION

BM 24 series bimetallic steam traps and air eliminators are simple and robust traps, recommended for steam process applications where condensate sensible heat can be recovered, steam tracing lines, drip points, storage tank coils, steam air venting, etc. The use of condensate sensible heat reduces the steam consumption.

Connections are female screwed or flanged.

MAIN FEATURES

- Modulating discharge.
- Discharges condensate below steam temperature.
- Excellent air discharge.
- Operates on superheated steam.
- Unaffected by waterhammer and vibrations.
- Built-in strainer.

USE: Saturated and superheated steam.

AVAILABLE

MODELS: BM24

SIZES: DN11/2" – DN2" ;DN 40 - DN 50

CONNECTIONS: Female screwed BSP or NPT
Flanged EN 1092-1 PN40 or ANSI
SW - Socket weld to ANSI B 16.11
BW - Butt weld to ANSI B16.25

INSTALLATION: Horizontal installation
See IMI installation and maintenance instructions.

PMA – Max. allowable pressure 32 bar

TMA – Max. allowable temperature 300 °C

PMO – Max. operating pressure 24 bar

TMO –Max. Operating temperature 250 °C

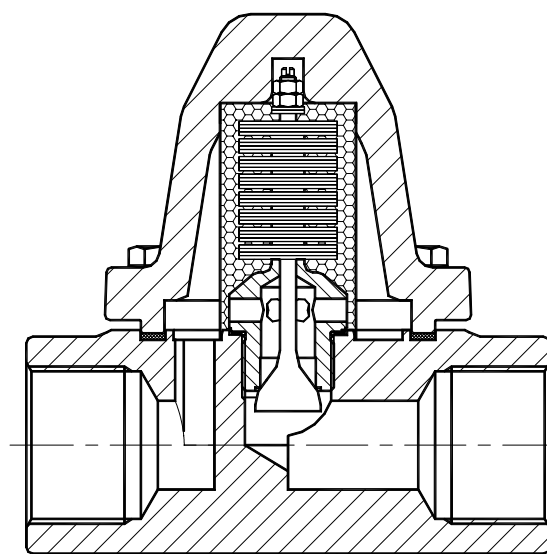
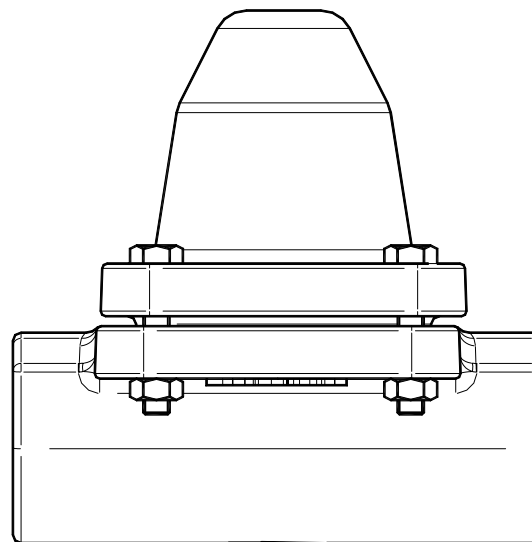

How to order:i.e. BM24 DN11/2" BSP

CE MARKING (PED - European Directive 97/23/EC)	
PN 40	Category
DN40 - DN50	1 (CE Marked)

FLOW RATE CAPACITY IN Kgs/h													
MODEL	SIZE	DIFFERENTIAL PRESSURE (bar)											
		0,5	1	2	4	6	8	10	12	16	18	20	24
BM 24	40 - 50 A	700	900	1200	1450	1600	1700	1780	1880	1900	1950	2020	2100
BM 24	40 - 50 B	1900	2400	3500	4900	5500	6050	7000	7200	7800	8400	8800	9000

A = Condensate discharge at 10°C below saturation temperature. B = Cold water capacity at about 20°C.

MATERIALS		
POS. Nr.	DESIGNATION	MATERIAL
1	Body	ASTM A105 / 1.0432 (Equiv.P250GH)
2	Cover	ASTM A105 / 1.0432 (Equiv.P250GH)
3	* Gasket	St.St./Graphite
4	* Valve assembly	Hardened St.Steel / Bimetal
5	* Strainer screen	AISI304 / 1.4301
6	* Seat gasket	Copper
7	Studs	ASTM A193 Gr.B7
7A	Nuts	ASTM A194 Gr.2H

* Available spare parts

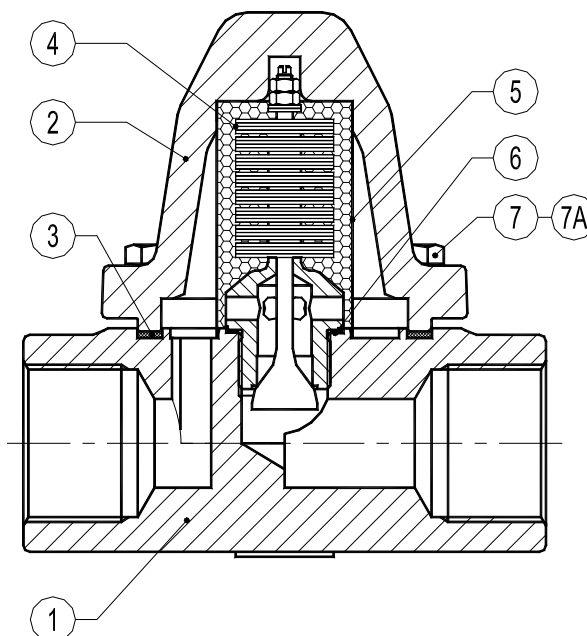

DIMENSIONS (mm)													
SIZE DN	BSP - NPT - SW - BW				EN 1092-1 PN40			ANSI 150			ANSI 300		
	A	C	D	WGT. Kgs	B	F*	WGT. Kgs	B	F*	WGT. Kgs	B	F*	WGT. Kgs
1 1/2" - 40	160	132	115	7,2	75	230	11,9	64	230	10,6	78	230	12,9
2" - 50	230	132	115	9,3	83	230	14,9	76	230	14,5	83	230	16,1

* Note: different face to face dimensions on request.

