

BIMETALLIC STEAM TRAPS AND AIR ELIMINATORS BM 35 (DN1/2" – DN 1" ; DN15 – DN25)

DESCRIPTION

BM35 series bimetallic steam traps and air eliminators are simple and robust traps, recommended for steam where condensate sensible heat can be recovered, steam tracing lines, drip points, storage tank coils, steam air venting, etc. The use of condensate sensible heat reduces the steam consumption.

Connections are female screwed, socket weld, butt weld or flanged.

MAIN FEATURES

- Modulating discharge.
- Discharges condensate below steam temperature.
- Excellent air discharge.
- Operates on superheated steam.
- Unaffected by water hammer and vibrations.
- Built-in strainer.

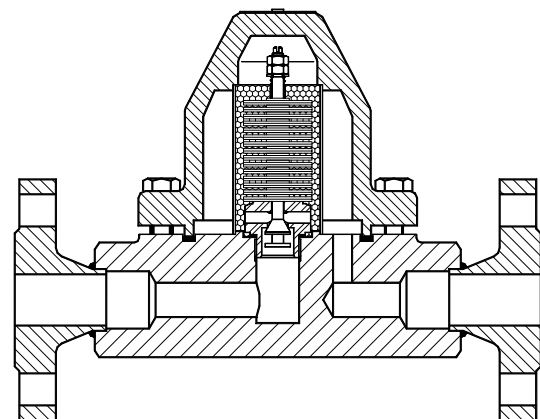

- USE: Saturated and superheated steam.
- AVAILABLE MODELS: BM35
- SIZES: DN 1/2" to 1" ; DN15 to DN25.
- CONNECTIONS: Female screwed BSP or NPT
Flanged EN 1092-1 or ANSI
SW - Socket weld to ANSI B 16.11
BW - Butt weld to ANSI B16.25
- INSTALLATION: Horizontal installation recommended, can be installed in any position. See IMI installation and maintenance instructions.

BM35 LIMITING CONDITIONS PN63 - ANSI 400	
ALLOWABLE PRESSURES	RELATED TEMPERATURE
63 bar	300 °C
35 bar	425 °C

Operating pressure : 2 to 35 bar

FLOW RATE CAPACITY IN Kgs/h															
MODEL	SIZE	DN	DIFFERENTIAL PRESSURE (bar)												
			2	4	6	8	10	12	16	18	20	24	26	32	35
BM 35	15 - 25	A	550	780	880	900	920	935	950	980	1000	1030	1080	1130	1160
BM 35	15 - 25	B	1500	1700	2000	2200	2500	2700	2990	3150	3400	3750	3880	4030	4200

A = Condensate discharge at 10°C below saturation temperature. B = Cold water capacity at about 20°C.

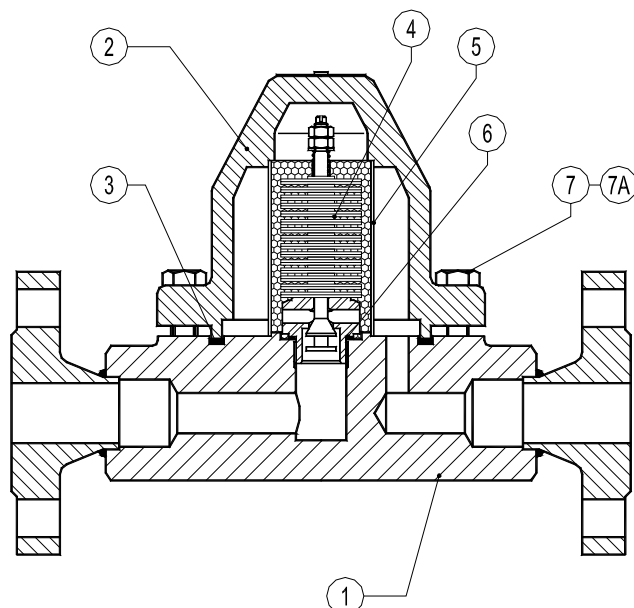

MATERIALS		
POS. Nr.	DESIGNATION	MATERIAL
1	Body	ASTM A105 / 1.0432 (Equiv.P250GH)
2	Cover	ASTM A105 / 1.0432 (Equiv.P250GH)
3	* Gasket	St.St./Graphite
4	* Valve assembly	Hardened St.Steel
5	* Strainer screen	AISI304 / 1.4301
6	* Seat gasket	AISI304 / 1.4301
7	Studs	ASTM A193 Gr.B7
7A	Nuts	ASTM A194 Gr.2H

* Available spare parts

DIMENSIONS (mm)																	
BSP - NPT - SW - BW					EN 1092-1PN40			ANSI 300			EN 1092-1 PN63 / PN100			ANSI 400 / 600			
SIZE DN	A	C	D	WGT. Kgs	B	F*	WGT. Kgs	B	F*	WGT. Kgs	B	F*	WGT. Kgs	B	F*	WGT. Kgs	
15	160	120	115	6,3	47,5	230	7,9	47,5	230	8,2	52,5	230	8,8	47,5	230	8,2	
20	160	120	115	6,3	52,5	230	8,5	59	230	9,4	65	230	11,1	59	230	9,4	
25	160	120	115	6,3	57,5	230	9,1	62	230	10,2	70	230	11,8	62	230	10,2	

* Note: different face to face dimensions on request.

