

DIAPHRAGM SENSING PRESSURE REDUCING VALVE P15SS DN 1/4" – 1/2" ; DN15

DESCRIPTION

The ADCA P15 series **direct acting, springloaded diaphragm sensing**, pressure reducing valves, are designed for use on compressed air, water and other gases or liquids compatible with the materials of construction.

They are suitable for pressure reducing stations where low capacity is required.

Connections are female screwed or flanged.

MAIN FEATURES

Compact design.

Machined from barstock materials.



OPTIONS:

Metal to metal or soft valve.
Relieving-Internal relief valve to allow reduce outlet pressure in a no-flow condition.
Built-in strainer.
Outlet 1/4" gauge connection on body.
Panel mounting nut and thread.
Straight or angle connections.

USE:

Compressed air, water and other gases and liquids compatible with the construction.
Special version available for steam, on request.

AVAILABLE MODELS:

P15SS – Stainless steel.

SIZES:

DN 1/4", 3/8" and 1/2".
DN 15

CONNECTIONS:

Female screwed ISO7/1Rp(BS 21) or NPT.
Flanged EN 1092-1 PN40 / PN63
Special flanges upon request.

INSTALLATION:

Horizontal installation.
An "Y" strainer should be provided upstream the valve.
See IMI, installation and maintenance instructions

ORDER REQUIREMENTS:

Type of fluid
Maximum operating temperature
Inlet pressure and required outlet pressure
Capacity (maximum and minimum).

CAPACITIES			
Valve Size	1/4"	3/8"	1/2"
KVs (m3/h)	1,15	1,15	1,35

LIMITING CONDITIONS	
Valve model	PRV30SS
Body design conditions	PN 63
Max.upstream pressure	50 bar
Max.downstream pressure	15 bar
Min.downstream pressure	0,2 bar
Max.design temperature *	80 °C
Max.recommended reducing ratio	40:1

*Other on request.

CE MARKING (PED - European Directive 97/23/EC)	
PN 16-PN63	Category
DN 8 to 15	SEP - art. 3, paragraph3

DIMENSIONS (mm)-Screwed						EN 1092-1 Flanges		
SIZE DN	A	A1	B	C	WGT. Kgs	D*	E	WGT. Kgs
1/4"	80	60	20	170	2,4	-	-	-
3/8"	80	70	20	170	2,8	-	-	-
1/2"-15	80	-	20	170	3,3	150	47,5	4,7

* Different lengths on request.

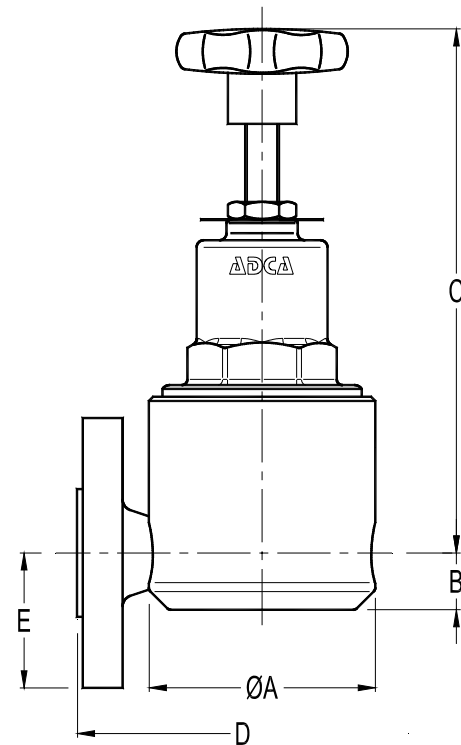
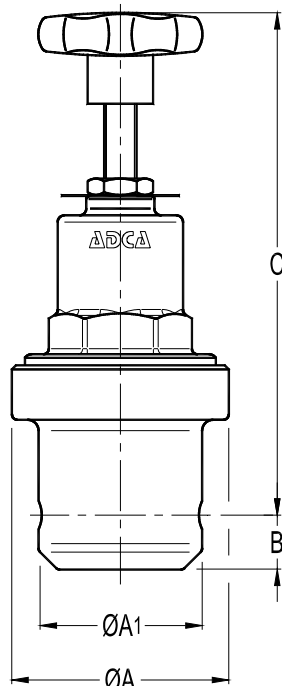

MATERIALS		
POS.	DESIGNATION	MATERIAL
1	VALVE BODY	AISI316 / 1.4401 ; CF8M / 1.4408
2	TOP COVER	AISI316 / 1.4401 ; CF8M / 1.4408
3	SEAT	AISI316 / 1.4401
4	* GASKET	AISI304 / 1.4301
5	PUSHROD	AISI316 / 1.4401
6	* VALVE HEAD	NBR-EPDM-PTFE,etc
8	* VALVE SPRING	AISI302 / 1.4300
9	* STRAINER SCREEN	AISI304 / 1.4301
10	* DIAPHRAGM	AISI301 / 1.4310
11	* GASKET	ST.STEEL GRAPHITE
12	* GASKET	AISI304 / 1.4301
13	SPRING PLATE	BRASS
15	* ADJUSTMENT SPRING	SPRING STEEL
16	TOP SPRING PLATE	BRASS
17	ADJUSTMENT SCREW	AISI304 / 1.4301
18	LOCKNUT	ST.STEEL A2-70
19	HANDWHEEL	PLASTIC
20	SPRING IDENT. PLATE	ALUMINIUM

* Available spare parts.

Remarks: All valves has a serial number. In case of non-standard valves this number must be supplied if spare parts are ordered.

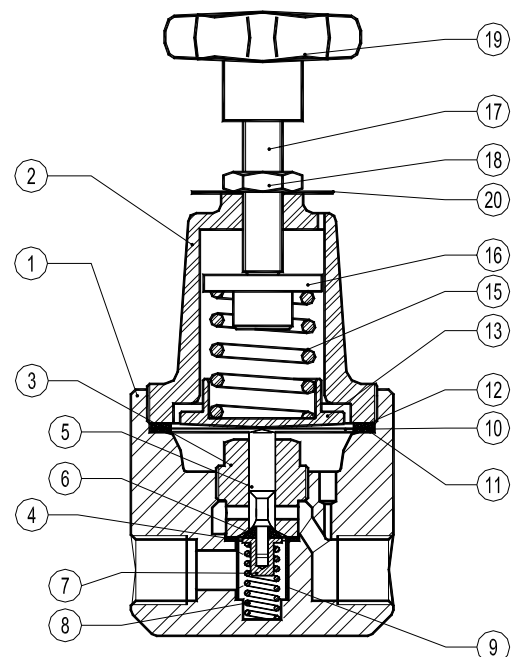



ORDERING CODES P15											
Valve Model	P15	.	1	W	N	C	R		.	A	15
P15SS - Diaphragm sensing	P15										
Outlet spring range											
N°1 - 0,2 to 1,5 bar			1								
N°2 - 0,3 to 3 bar			2								
N°3 - 0,8 to 8 bar			3								
N°4 - 1,5 to 15 bar			4								
Aplication											
Water				W							
Gases				G							
Oxygen (Degreased)				O							
Seal material											
NBR					N						
EPDM					E						
PTFE					T						
FPM/VITON					V						
Maximum inlet pressure											
30 bar						C					
50 bar a)						D					
Diaphragm material											
Stainless steel (Non-relieving)							S				
Rubber/PTFE (Relieving or non-relieving)							R				
Gauge port 1/4"											
Without gauge ports								(1)			
Gauge port on the left side (Related to the flow direction)								4			
Gauge port on the right side (Related to the flow direction)								3			
Gauge ports on both sides								2			
Relieving											
Non-relieving								(1)			
Relieving (Only for non-dangerous gases)								R			
Pipe connection											
Threaded BSP ISO 7/1 Rp										A	
Threaded NPT ANSI B1.20.1										C	
Socket weld SW ANSI B16.11										H	
Butt weld BW ANSI B16.25										I	
Flanged EN1092-1 PN40										N	
Flanged EN1092-1 PN63										O	
Flanged ANSI B16.5 150#										U	
Flanged ANSI B16.5 300#										V	
Flanged ANSI B16.5 600#										W	
Size											
DN 1/4"											08
DN 3/8"											10
DN 1/2" or DN 15											15
Special valves / Extras b)											E

(1) Omitted if a standard valve is requested

a) The 50 bar inlet available only with spring N°4

b) Full description or additional codes has to be added in case of non-standard combination.