

HIGH ACCURACY PRESSURE REDUCING VALVE PRV 300 DN 1/2" – 3/4" ; DN15 – DN20

DESCRIPTION

The ADCA PRV300 series **direct acting, spring-loaded diaphragm sensing, balanced plug** pressure reducing valves, are designed for use on compressed air, water and other gases or liquids compatible with the materials of construction.

They are suitable for high accuracy pressure reducing stations at the point of use on laundry machines, dyeing, food industries, sterilizers, etc.

Connections are female screwed or flanged.

MAIN FEATURES

Compact design.

Large high accuracy diaphragm.

Balanced valve plug

Machined from barstock materials and investment casting



OPTIONS:

Different soft valves for water and gases.
Relieving-Internal relief valve to allow reduce outlet pressure in a no-flow condition.

Built-in strainer.

Outlet 1/4" gauge connection on body.

Regulating screw with top cap.

USE:

Compressed air, water and other gases and liquids compatible with the construction.

AVAILABLE

MODELS:

PRV300/SS – Stainless steel

SIZES:

DN 1/2" and 3/4"

DN 15 and DN20

CONNECTIONS:

Female screwed ISO7/1Rp(BS 21).

Flanged EN 1092-1 PN40 or ANSI.

INSTALLATION:

Horizontal installation.

An "Y" strainer should be provided upstream the valve.

See IMI, installation and maintenance instructions.

ORDER

REQUIREMENTS :

Type of fluid

Maximum operating temperature

Inlet pressure and required outlet pressure

Capacity (maximum and minimum).

CAPACITIES		
Valve Size	15	20
KVs (m3/h)	2,1	2,4

LIMITING CONDITIONS	
Valve model	PRV300SS
Body design conditions	PN 16
Max.upstream pressure	16 bar
Max.downstream pressure	3 bar
Min.downstream pressure	0,1 bar
Max.design temperature *	80 °C
Max.recommended reducing ratio	40:1

*Other on request.

CE MARKING (PED - European Directive 97/23/EC)	
PN 16	Category
DN 15 to 20	SEP - art. 3, paragraph3

DIMENSIONS (mm)-Screwed						EN 1092-1 Flanges		
SIZE DN	A	B	C	D	WGT. Kgs	E	F*	WGT. Kgs
1/2"-15	80	38	185	160	3,9	47,5	260	5,3
3/4"-20	80	38	185	160	3,9	52,5	260	5,9

* Different lenghts on request.

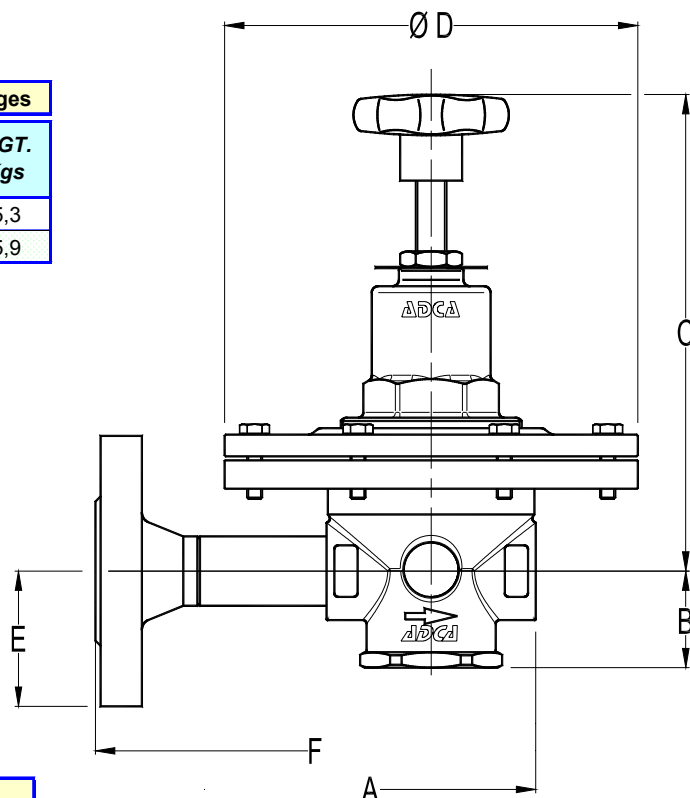

MATERIALS		
POS.	DESIGNATION	MATERIAL
1	VALVE BODY	AISI316 / 1.4401 ; CF8M / 1.4408
2	COVER	AISI316 / 1.4401
2A	SPRING COVER	AISI316 / 1.4401 ; CF8M / 1.4408
2B	BOLTS	ST.STEEL A2-70
3	SEAT COVER	AISI316 / 1.4401
4	O-RING	NBR
5	PISTON VALVE	AISI316 / 1.4401
6	VALVE HEAD	NBR
6A	PUSHROD	AISI316 / 1.4401
7	O-RING	NBR
8	VALVE SPRING	AISI302 / 1.4300
8A	STRAINER SCREEN	AISI304 / 1.4301
9	PUSHER DISC	AISI304 / 1.4301
10	DIAPHRAGM	RUBBER
13	SPRING PLATE	AISI304 / 1.4301
14	NUT	ST.STEEL A2-70
15	ADJUSTMENT SPRING	STEEL
16	TOP SPRING PLATE	BRASS
17	ADJUSTMENT SCREW	AISI304 / 1.4301
18	LOCKNUT	ST.STEEL A2-70
19	HANDWHEEL	PLASTIC
20	SPRING IDENT. PLATE	ALUMINIUM

* Available spare parts.

Remarks: All valves has a serial number. In case of non-standard valves this number must be supplied if spare parts are ordered.

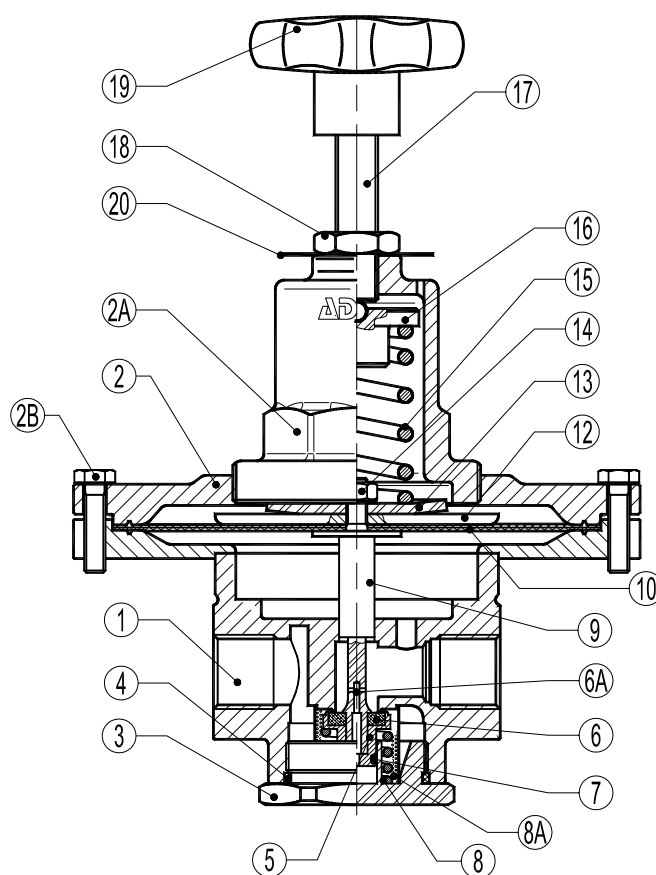



ORDERING CODES PRV300SS											
Valve Model	R300	.	1	W	N	C	R				15
PRV300SS - Diaphragm sensing	R300										
Outlet spring range											
N°0 - 0,1 to 1 bar			1								
N°1 - 0,2 to 1,5 bar			1								
N°2 - 0,3 to 3 bar			2								
Aplication											
Water				W							
Gases				G							
Oxygen (Degreased)				O							
Seal material											
NBR					N						
EPDM					E						
PTFE					T						
FPM/VITON					V						
Maximum inlet pressure											
16 bar						B					
Diaphragm material											
Rubber/PTFE (Relieving or non-relieving)							R				
Gauge port 1/4"											
Without gauge ports								(1)			
Gauge port on the left side (Related to the flow direction)								4			
Gauge port on the right side (Related to the flow direction)								3			
Gauge ports on both sides								2			
Relieving											
Non-relieving								(1)			
Relieving (Only for non-dangerous gases)								R			
Pipe connection											
Threaded BSP ISO 7/1 Rp										A	
Threaded NPT ANSI B1.20.1										C	
Socket weld SW ANSI B16.11										H	
Butt weld BW ANSI B16.25										I	
Flanged EN1092-1 PN40										N	
Flanged EN1092-1 PN63										O	
Flanged ANSI B16.5 150#										U	
Flanged ANSI B16.5 300#										V	
Flanged ANSI B16.5 600#										W	
Size											
DN 1/2" or DN 15											15
DN 3/4" or DN 20											20
....											25
											32
											40
											50
Special valves / Extras b)											E

(1) Omitted if a standard valve is requested

b) Full description or additional codes has to be added in case of non-standard combination.