

PILOT OPERATED PRESSURE REDUCING VALVES PRV47 (Steel) PRV47I (St.Steel)

DESCRIPTION

The ADCA PRV47 pilot operated pressure reducing valves are designed for use on steam, compressed air, nitrogen and other gases compatible with the construction and they can be installed on pressure reducing stations throughout all industries.

Connections are flanged or threaded.

MAIN FEATURES

Robust totally steel or stainless steel construction.

Suitable for dead end conditions.

Guided piston and valve stem.

Hardened plug.

OPTIONS: Soft faced valve plug for gases and steam
Special pressure top for low pressures
Drain connection in bottom cover
Stellited plug and seat

USE: Saturated steam, compressed air and other gases (Group 2) compatible with the construction (except oxygen).

AVAILABLE MODELS:

PRV47 - standard model for steam
PRV47G -compressed air and gases

VALVE SIZES: DN15 to DN50

CONNECTIONS: Flanged EN 1092-1 or ANSI
Threaded BSP, NPT, SW.

INSTALLATION: Horizontal installation.
An "Y" strainer, steam separator and steam trap should be provided upstream the valve.
See IMI, installation and maintenance instructions.

ORDER REQUIREMENTS:

Type of fluid
Maximum operating temperature
Inlet and outlet pressure
Flow rate (maximum and minimum)

HOW TO SELECT: Never size the valve according to the pipe diameter in which it has to be fitted but according to the required actual flow of fluid.

Refer to valve calculation table or consult the factory.

CE MARKING (PED - European Directive 97/23/EC)	
PN 40	Category
DN15 to DN32	SEP - art. 3, paragraph3
DN40 to DN50	1 (CE Marked)



VALVE LIMITING CONDITIONS: Body design conditions: PN40
40 bar at 120°C
32 bar at 239°C
28 bar at 300°C
Min.working temperature: -10°C
Maximum upstream pressure (steam) : 25 bar
Maximum upstream pressure (air) : 31 bar
Maximum downstream pressure: 17 bar
Minimum downstream pressure : 0,35 bar*
* 0,07 bar with low pressure top (limited at 7 bar inlet).
Pressure and temperature may change if soft seating or piston rings are used.

USEFUL NOTES ON VALVE AND PIPE SIZING

A special low pressure top assembly should be fitted for outlet pressures from 0,07 up to 0,5 bar (Fig.2).
Two regulators in parallel should be used on larger systems where minimum flow is less than 10% of maximum. If the flow is unknown it is possible to estimate it based on pipe sizing or equipment heat requirement - please consult.
The balance pipe connection is recommend to enter downstream pipe at a minimum of 1 meter from valve.
A spool piece can be supplied to house the balancing pipe.

INSTALLATION

Installation instructions are available (IMI-PRV47) and typical assembling drawing. Special assembling design may be produced on request.

MATERIALS - PRV47 Steel construction		
POS.	DESIGNATION	MATERIAL
1	VALVE BODY	S355J2G3 / 1.0570 ; P250GH / 1.0460
2	PILOT VALVE BODY	CF8 / 1.4308
3	TOP COVER	C45E / 1.1191
3A	COVER NUT	C45E / 1.1191
3B	TOP COVER	C45E / 1.1191
3C	COVER NUT	C45E / 1.1191
4	*MAIN VALVE SEAT	AISI316 / 1.4401
5	*MAIN VALVE	HARDENED ST.STEEL
5A	*MAIN VALVE (SOFT)	SS316 W/ PTFE/GR; RULON,...
6	*MAIN VALVE SPRING	AISI 302 / 1.4300
7	*PISTON	BRONZE B62 / ASTM B148.97
8	*PISTON RINGS	BRONZE / FKM / EPDM / NBR
9	PISTON LINER	AISI304L / 1.4306
10	BOTTOM COVER	S355J2G3 / 1.0570
11	*BOTTOM COVER GASKET	ST.ST/GRAPHITE
12	*DIAPHRAGM	AISI301 / 1.4310
12A	*LOW PRESSURE DIAPHRAGM	AISI301 / 1.4310
13	*DIAPHRAGM GASKET	ST.STEEL/GRAPHITE
13A	*DIAPHRAGM GASKET	ST.STEEL/GRAPHITE
14	*PILOT VALVE GASKET	ST.STEEL/GRAPHITE
15	LOWER SPRING CARRIER	BRASS
16	*ADJUSTMENT SPRING	STEEL
16A	DIAPHRAGM SPRING	STAINLESS STEEL
17	TOP SPRING CARRIER	BRASS
18	SPRING IDENT. PLATE	ALUMINIUM
19	*PILOT VALVE	AISI316 / 1.4401
19A	*PILOT VALVE (SOFT)	PTFE/GR; RULON, ETC
20	*PILOT VALVE SEAT	AISI316 / 1.4401
21	*PILOT VALVE GASKET	COPPER
22	*PILOT VALVE SPRING	AISI302 / 1.4300
23	HANDWHEEL	PLASTIC/ST.STEEL
23A	LOCKNUT	AISI304 / 1.4301
24	BOLTS	STEEL 10.9
24C	BOLTS	STEEL 10.9
25	COMPRESSION FITTING	PLATED CARBON STEEL
26	BALANCE PIPE	COPPER
27	*PILOT VALVE STRAINER	AISI304 / 1.4301
28	STRAINER NUT	AISI304 / 1.4301
29	GASKET	COPPER
100	* PRESSURE REGULATOR (Relieving)	ADCA P-10
102	** STEAM TRAP	ADCA TH-21
103	** GLOBE VALVE	ADCA GV32B
104	** DRAIN CONNECTION NIPPLE	STEEL DN1/2" x 3/8"
105	SOLENOID VALVE	BRASS
106	SUSTAINING VALVE	ADCA PS15
107	STRAINER	ADCA IS1001-ST.STEEL

* Available spare parts

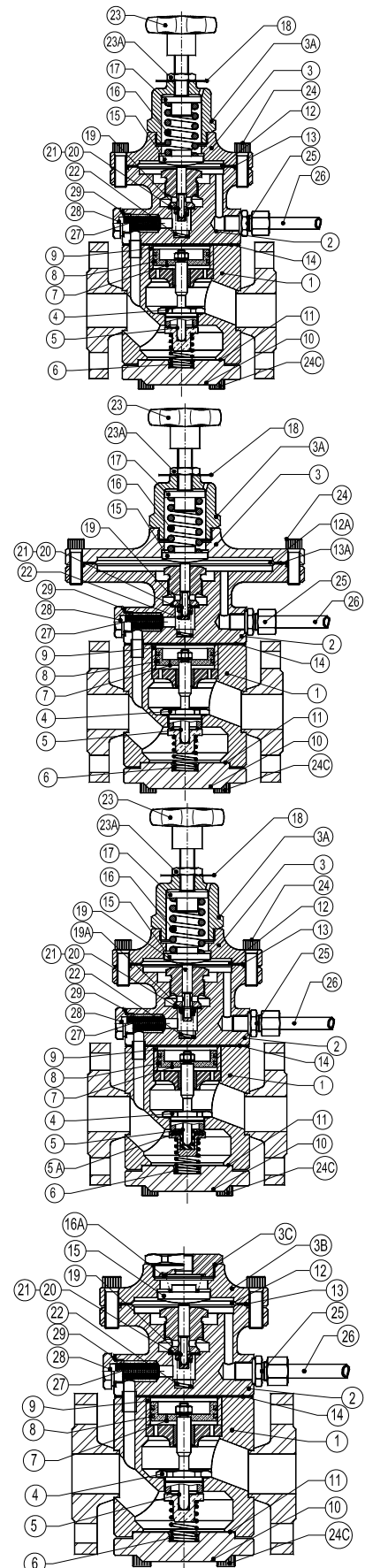

MATERIALS - PRV47I Stainless steel construction		
POS.	DESIGNATION	MATERIAL
1	VALVE BODY	AISI316 / 1.4401
2	PILOT VALVE BODY	CF8 / 1.4308
3	TOP COVER	AISI316 / 1.4401
3A	COVER NUT	AISI316 / 1.4401
3B	TOP COVER	AISI316 / 1.4401
3C	COVER NUT	AISI316 / 1.4401
4	*MAIN VALVE SEAT	AISI316 / 1.4401
5	*MAIN VALVE	HARDENED ST.STEEL
5A	*MAIN VALVE (SOFT)	SS317 W/ PTFE/GR / RULON,...
6	*MAIN VALVE SPRING	AISI302 / 1.4300
7	*PISTON	STAINLESS STEEL
8	*PISTON RINGS	BRONZE / FKM/ EPDM / NBR
9	PISTON LINER	AISI304L / 1.4306
10	*BOTTOM COVER	AISI316 / 1.4401
11	*BOTTOM COVER GASKET	ST.ST/GRAPHITE / PTFE
12	*DIAPHRAGM	AISI301 / 1.4310
12A	*LOW PRESSURE DIAPHRAGM	AISI301 / 1.4310
13	*DIAPHRAGM GASKET	ST.STEEL/GRAPHITE
13A	*DIAPHRAGM GASKET	ST.STEEL/GRAPHITE
14	*PILOT VALVE GASKET	ST.STEEL/GRAPHITE
15	LOWER SPRING CARRIER	BRASS / ST.STEEL
16	*ADJUSTMENT SPRING	STEEL / ST.STEEL
16A	DIAPHRAGM SPRING	STAINLESS STEEL
17	TOP SPRING CARRIER	BRASS
18	SPRING IDENT. PLATE	ALUMINIUM / ST.STEEL
19	*PILOT VALVE	AISI316 / 1.4401
19A	*PILOT VALVE (SOFT)	PTFE/GR; RULON, ETC
20	*PILOT VALVE SEAT	AISI316 / 1.4401
21	*PILOT VALVE GASKET	COPPER / PTFE
22	*PILOT VALVE SPRING	AISI302 / 1.4300
23	HANDWHEEL	PLASTIC/ST.STEEL
23A	LOCKNUT	AISI304 / 1.4301
24	BOLTS	ST.STEEL A-4
24C	BOLTS	ST.STEEL A-4
25	COMPRESSION FITTING	STAINLESS STEEL
26	BALANCE PIPE	STAINLESS STEEL
27	*PILOT VALVE STRAINER	AISI304 / 1.4301
28	STRAINER NUT	AISI304 / 1.4301
29	GASKET	COPPER / PTFE
100	** PRESSURE REGULATOR (Relieving)	ADCA P-10
102	** STEAM TRAP	ADCA TH-21
103	** GLOBE VALVE	ADCA GV32B
104	** DRAIN CONNECTION NIPPLE	STAINLESS STEEL DN1/2" x 3/8"
105	SOLENOID VALVE	STAINLESS STEEL
106	SUSTAINING VALVE	ADCA PS15 - ST.STEEL
107	STRAINER	ADCA IS100I -ST.STEEL

*Available spare parts

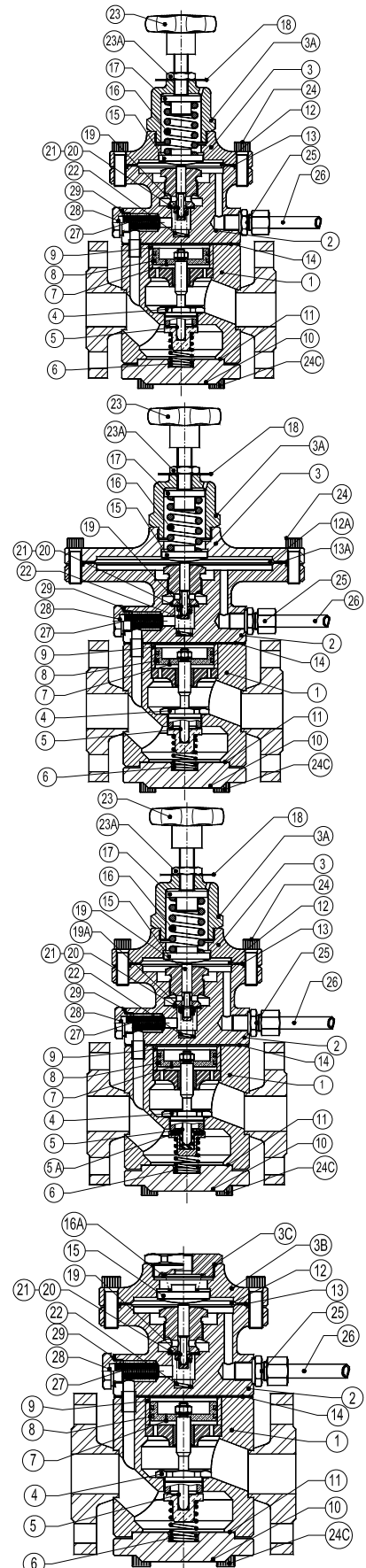

PRESSURE RANGES IN bar		
SPRING COLOUR	GREEN W/1 Diaphragm	BLACK W/2 Diaphragms
Red. Pressure	0,07 to 0,5 bar *	2 to 17 bar **
Red. Pressure	0,35 to 4 bar **	/

* With low pressure top; **Standard diaphragm.

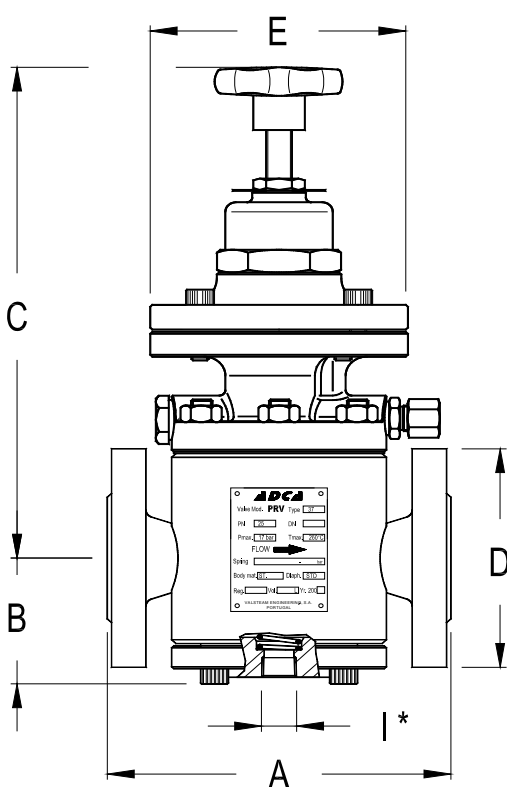

Fig.1

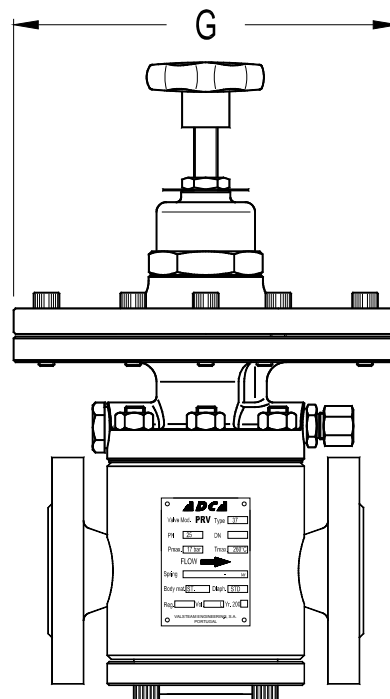

Fig.2

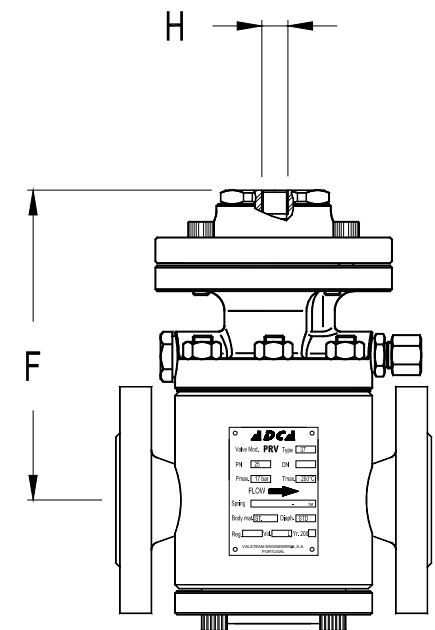

Fig.3

Fig.1 - Valve with standard diaphragm; Fig.2 - Valve with low pressure top; Fig.3 - Valve with compressed air top.

* Drain connection (option) for steam trapping . This drain connection does not replace the separator but can be useful if for example the valve stops operation for large periods.

DIMENSIONS - VALVE BODY (mm)										
DN	A * EN1092-1 Flanges	B	C	D	E	F	G	H	I	WEIGHT Kgs
15	150	56	275	95	120	162	195	1/4"	3/8"	13
20	150	56	287	105	120	174	195	1/4"	3/8"	13,5
25	160	56	287	115	120	174	195	1/4"	3/8"	14
32	180	68	299	140	120	186	195	1/4"	3/8"	18
40	200	75	307	150	130	194	195	1/4"	3/8"	22
50	230	84	323	165	160	210	195	1/4"	3/8"	31

* For ANSI flanges face to face dimensions, please consult.

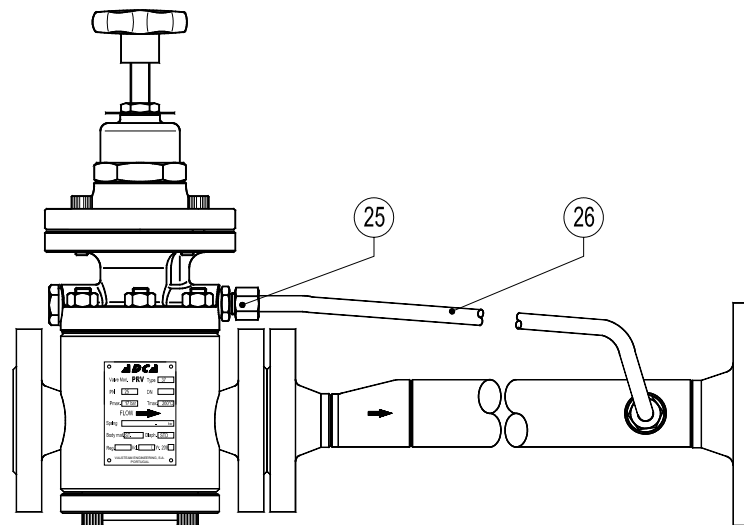

Fig.4

PRV 47 Standard for steam, compressed air or gases (Fig.4)

Description of operation: the high pressure upstream fluid is admitted to the valve and pilot valve. By compressing the regulating spring over the diaphragm, the pilot valve opens admitting regulated pressure on the top of the piston, which opens the main valve allowing the flow. The downstream pressure is then transmitted through the balance pipe, acting on the underside of the diaphragm.

Any downstream pressure increase deflects the diaphragm and the pilot valve closes, thus shutting off regulated gas to the piston which in turn closes the main valve assisted by the upstream pressure and loading spring. When the correct downstream pressure is achieved, the valve opens again, repeating the already described operation.

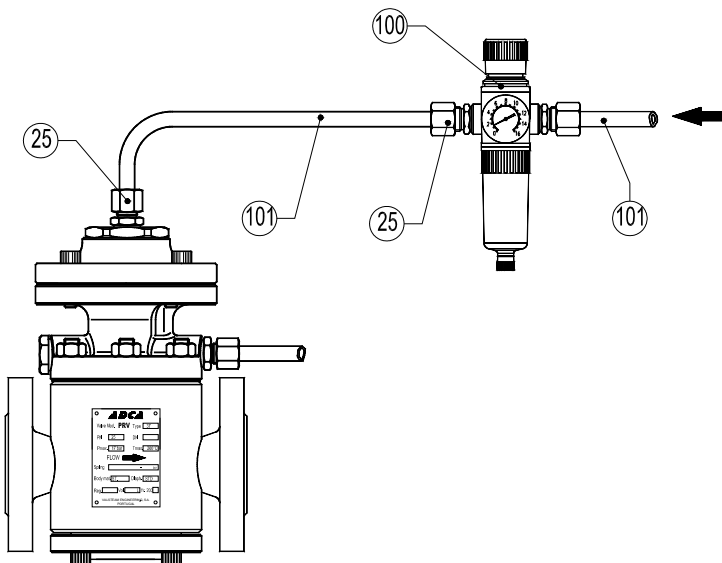

Fig.5

PRV47 valve with compressed air top for remote control (Fig.5)

The regulating spring force is placed by a compressed air signal.

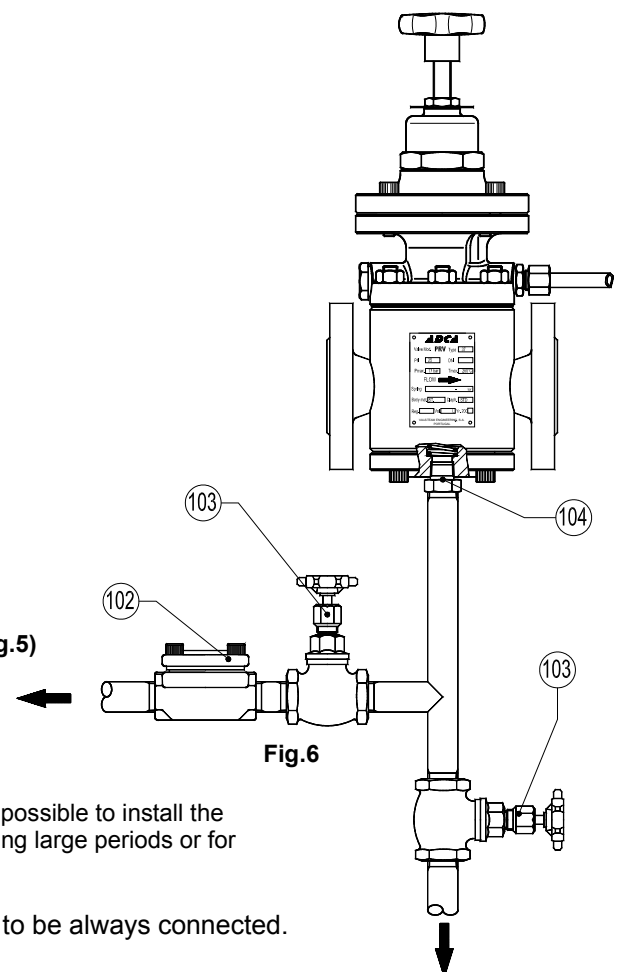

Fig.6

PRV47 with drain connection (Fig.6)

The optional drain connection is specially recommended when it is not possible to install the humidity separator close to the valve, when the valve is on no-flow during large periods or for system cleaning during start up.

Important: the balance pipe nr.26 (supplied with the valve) has to be always connected.

PRV47E with solenoid valve for electric remote control (Fig.7)

This valve version operates like the standard valve but it allows a remote control closure by means of a switching or timer control. When closing the solenoid valve, the pressure signal to the pilot valve is interrupted and thus also the main valve remains closed.

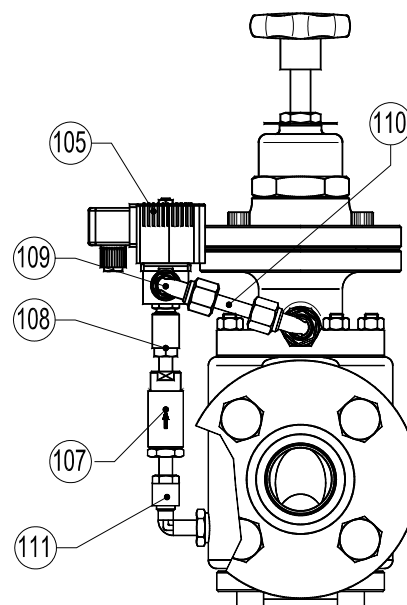

Fig.7

PRS47 pressure reducing and sustaining valve (Fig.8)

This version is a combination of pressure reducing valve and pressure sustaining valve. Compressing the spring of the PS15 (nr.106) pressure sustaining valve the same is closed till a desired set pressure, interrupting the signal to the PRV47 pilot valve and consequently it will remain closed. Since the pressure supply to the PS15 valve reaches the desired set pressure it will allow the flow and fluid signal to the PRV47 pilot valve, it will then work as already described.

PS47 pressure sustaining valve (available on request)

The pressure sustaining valves are particularly recommended in those systems where a limited flow rate is available and it is necessary to guarantee the supply to some critical process applications. Installing this valve in the supply of non-critical application limited to the minimum required pressure, they will close in case of excess of consumption and consequent pressure drop in the system, keeping the remaining flow available for the critical application. In general this valve maintains the upstream pressure under control.

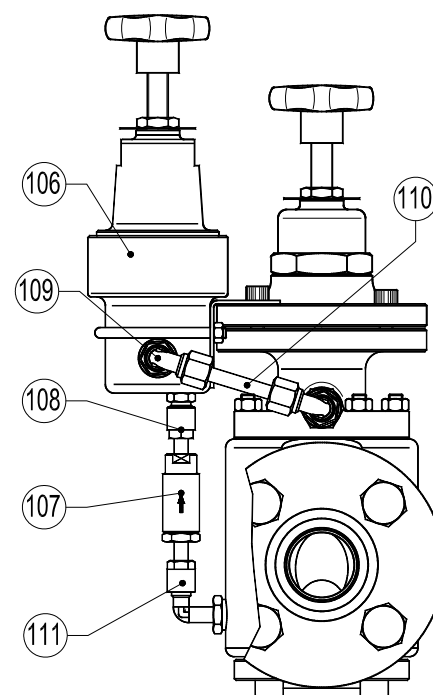

Fig.8



STEAM EQUIPMENT

PRV 47 - STEAM CAPACITY TABLE (Kg/h)							
INLET bar	OUTLET bar	SATURATED STEAM					
		DN15	DN20	DN25	DN32	DN40	DN50
0,7	0,35	40	75	125	190	280	480
1	0,4	45	95	160	240	355	620
	0,6	40	83	140	210	308	535
2	0,4 ÷ 1	75	150	250	380	545	960
	1,2	65	138	230	345	515	900
	1,6	50	105	175	265	393	685
3	0,4 ÷ 1,5	100	200	335	510	750	1310
	2	85	170	290	450	660	1155
	2,2	80	165	277	416	613	1050
	2,6	60	127	203	315	467	818
4	0,4 ÷ 2	125	250	420	630	920	1580
	2,5	114	225	385	580	850	1465
	3,2	92	183	309	482	708	1205
	3,6	68	137	237	353	536	932
5	0,4 ÷ 2	150	310	512	755	1114	1895
	3	144	295	488	743	1095	1835
	4	115	225	373	578	846	1430
	4,2	105	213	343	525	770	1342
6	0,4 ÷ 3	175	355	602	919	1358	2298
	4	159	314	538	827	1217	2142
	5	119	250	411	637	941	1644
	5,2	109	217	360	568	839	1465
7	0,4 ÷ 3,5	197	410	670	1005	1540	2644
	5	178	358	587	908	1345	2306
	6	132	271	452	688	1027	1773
	6,2	122	251	416	635	934	1618
8	0,4 ÷ 4	225	471	778	1169	1759	3043
	5	221	339	730	1118	1659	2884
	6	192	385	639	976	1451	2513
	7	146	293	481	732	1085	1887
	7,2	137	274	453	692	1011	1782
9	0,4 ÷ 5	251	518	856	1325	1923	3358
	6	241	500	788	1222	1766	3095
	7	206	398	679	1068	1559	2676
	8	156	314	514	794	1142	2053
	8,2	145	292	483	741	1090	1888
10	0,4 ÷ 5	275	561	944	1468	2127	3718
	6	272	551	917	1419	2074	3619
	7	252	508	838	1268	1871	3249
	8	213	431	722	1118	1659	2831
	9	163	333	548	843	1244	2152
12	0,4 ÷ 5	150	298	493	756	1143	1929
	1 ÷ 6	330	680	1124	1732	2541	4407
	8	311	629	1023	1575	2332	4034
	10	265	533	812	1271	1867	3202
	11	175	364	568	924	1350	2359
15	1 ÷ 8	408	839	1373	2138	3118	5403
	12	339	656	1068	1629	2441	4250
	14	199	401	662	1017	1503	2619
17	1 ÷ 9	425	863	1460	2178	3165	5343
	15	347	709	1190	1816	2694	4712
	16	207	416	717	1217	1608	2824
20	1 ÷ 12	541	1062	1774	2746	4001	6971
	15	459	931	1552	2335	3476	6184
	17	391	648	988	1748	2840	4698
25	2,5 ÷ 12	685	1337	2191	3360	4971	8392
	15	680	1320	2183	3356	4877	8284
	17	641	1256	2084	3156	4670	7866
28	5 ÷ 15	781	1521	3355	3864	5611	9862
	17	763	1471	3259	3768	5506	9652

PRV 47 - COMP. AIR CAPACITY TABLE (Nm3/h-0°C-1,013bar)							
INLET bar	OUTLET bar	COMPRESSED AIR					
		DN15	DN20	DN25	DN32	DN40	DN50
0,7	0,35	15	31	50	70	111	191
1	0,4	16	33	51	79	113	194
	0,6	27	55	90	138	199	343
2	0,4 ÷ 1	60	122	201	307	444	763
	1,2	54	109	180	276	399	686
	1,6	45	91	150	230	333	572
3	0,4 ÷ 1,5	120	240	300	460	666	1150
	2	105	210	251	384	555	1050
	2,2	48	93	152	232	334	570
	2,6	45	61	101	154	223	384
4	0,4 ÷ 2	150	238	499	739	1089	1825
	2,5	135	208	449	568	978	1635
	3,2	119	177	398	492	867	1444
	3,6	60	124	202	154	444	763
5	0,4 ÷ 2	180	360	505	768	1110	1908
	3	165	330	556	691	997	1716
	4	151	298	404	613	885	1526
	4,2	136	285	383	582	840	1449
6	0,4 ÷ 3	210	468	696	1046	1523	2580
	4	195	437	646	969	1412	2389
	5	150	345	494	738	1079	1817
	5,2	135	315	443	664	968	1627
7	0,4 ÷ 3,5	240	480	804	1200	1740	2989
	5	210	421	701	1046	1524	2640
	6	150	301	499	756	1104	1829
	6,2	105	211	349	529	773	1280
8	0,4 ÷ 4	270	546	798	1353	1746	3411
	5	265	516	747	1276	1635	3220
	6	225	449	710	1125	1635	2762
	7	180	361	600	892	1296	2184
9	0,4 ÷ 5	301	612	1011	1507	2244	3789
	6	270	553	910	1359	1980	3474
	7	240	492	816	1230	1798	2970
	8	180	360	598	903	1288	2247
	8,2	165	329	547	826	1176	2056
10	0,4 ÷ 5	330	659	1116	1692	2412	4173
	6	314	628	1065	1615	2301	3983
	7	288	599	1004	1503	2202	3810
	8	240	492	806	1212	1770	3022
	9	192	360	658	898	1350	2280
12	0,4 ÷ 5	181	342	628	852	1283	2165
	1 ÷ 6	390	792	1300	1978	2844	4917
	8	360	732	1219	1827	2622	4497
	10	270	553	910	1359	1980	3474
	11	210	468	696	1046	1523	2580
15	1 ÷ 8	480	972	1602	2427	3564	6072
	12	375	762	1272	1923	2784	4692
	14	255	528	889	1332	1896	3398
17	1 ÷ 9	540	912	1819	2737	3984	6818
	15	315	708	1179	1764	2520	4418
	16	255	528	889	1332	1896	3398
20	1 ÷ 12	615	1254	2379	3153	4578	7911
	15	534	900	1799	2707	3940	6738
	17	450	901	1497	2246	3336	5796
25	2,5 ÷ 12	780	1590	2689	3982	5790	9902
	15	756	1530	2548	3828	5616	9600
	17	720	1464	2412	3707	5310	9123
28	5 ÷ 15	870	1770	2910	4430	6390	10950
	17	840	1724	2820	4320	6180	10680



ORDERING CODES PRV47										
Valve Model	VR.47		E	S.	1			1.	A	15
PRV47-standard steam use	VR.47									
PRV47G-compressed air and gases	VR.47G									
Material Construction										
Standard steel construction		(1)								
Stainless steel construction		I								
Remote Control and Pilots										
Solenoid valve 220V for remote closure up to 10 bar-180°C			E							
Pressure sustaining / reducing a)			S							
Pressure sustaining / reducing / solenoid			ES							
Diaphragm Type										
Standard diaphragm			S.							
Low pressure diaphragm			L.							
Outlet Pressure										
Green spring 0,35 to 5 bar - single diaphragm					1					
Black spring 2 to 17 bar - double diaphragm					4					
Pneumatic control top 0,35 to 5 bar - single diaphragm					6					
Pneumatic control top 2 to 17 bar - double diaphragm					7					
Piston Rings										
Bronze c)		(1)								
FKM c)			V							
EPDM c)			E							
NBR c)			N							
Drain Connection										
Standard valve							(1)			
Drain connection DN 3/8"							D			
Valve Plug										
Standard metal to metal with hardened plug								1.		
Stellited valve and plug								2.		
Soft plug - Virgin PTFE								3.		
Soft plug - PTFE/GR								4.		
Soft plug - Rulon								5.		
Connections										
Threaded BSP ISO 7/1 Rp									A	
Threaded NPT ANSI B1.20.1									C	
Flanged EN 1092-1 PN40									N	
Flanged ANSI B16.5 150#									U	
Flanged ANSI B16.5 300#									V	
SIZE										
DN 1/2" or DN15										15
DN 3/4" or DN20										20
DN										
Special valves / Extras b)										E

Remarks:

(1) Omitted if a standard valve is requested

a)PS15 Sustaining valve standard spring : 0,2 to 10 bar

b)Full description or additional codes has to be added in case of a non-standard combination .

c)Valve limited to maximum operating temperature materials