

ADCATROL FIELD I TO P CONVERTER PC 25

DESCRIPTION

Instrument for conversion of a standard d.c. current signal into a standard pneumatic signal, for the change-over from electrical controllers to pneumatic control valves, or from electrical measuring system to pneumatic controllers.

The PC25 is a force balance device, which converts the input signal 4...20 mA, a proportional output signal 3..15 psi (0,2...1 bar) or 6...18 psi (0,4...1,2 bar) , with a respective supply pressure of 1,7 - 5bar .

MAIN FEATURES

- Particularly compact design
- Good dynamic response
- Insensitive to mechanic vibrations
- Low maintenance and low consumption
- High reliability
- Adjustable output measuring span



TECHNICAL DATA

TECHNICAL DATA		
Pneumatic	Output pressure	Ranges 0,2 - 1bar ; 0,4 - 1,2 bar
	Air supply	Oil free, dry air, filtered to 5 microns, 1,7 to 5 bar.
	Flow capacity	Up to 300nl/min forward flow, 150 nl/min relief
	Air consumption	1,4 l/min typical
	Linearity	Maximum 0,5% of span
	Hysteresis	Maximum 0,35% of span
	Response time	Typically less than 0,5 seconds (dependent on input for 10-90% step change in outlet pressures) into a 10cc load.
	Temperature sensivity	< 0,1% span/°C for span and zero over operating range
	Supply sensitivity	Better than 0,075% span output change per % supply pressure change
	Port sizes	1/4" NPT
Physical	Operating temperature	-40C to 85°C
	I.P. Rating	IP65 in normal operation
	Electromagnetic compatibility	This is a passive electro-pneumatic instrument and is unaffected by interfering high frequency signals
	Material of construction	Zinc diecasting passivated and epoxy paint, nitrile diaphragms, Be2Cu flapper nozzle and supply valve
	Weight	825 g
	Mounting position	Integral surface mounting bracket provided for preferred vertical mounting.
	Vibration effect	<5% of span: 4mm 5-15Hz & 2g sine 15-150Hz, vertical, horizontal and inverted, in accordance with ISA-S75.13-1996
Electrical	Input signal	4-20mA
	Failure model	Output pressure falls to bleed pressure when electrical supply fails
	Connections	30mm square connector DN 43650
	Span/zero	Adjustable 20% output range
	Input impedance	11kohms for a 0-10V

MOUNTING DIMENSIONS

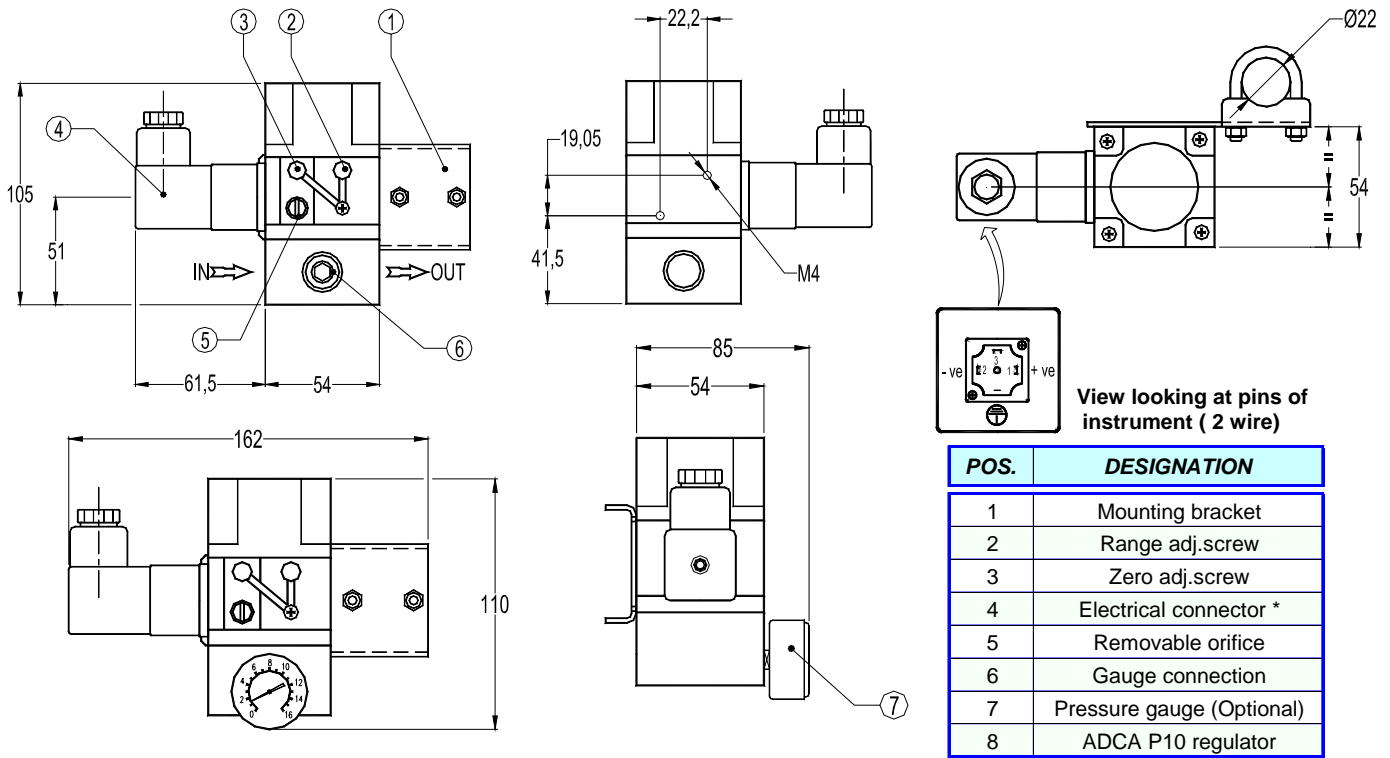

Assembling with pressure gauge (on request).

* Plug orients 4 ways

Calibration

When the instrument is first installed, or after a long period of downtime, a moderate zero shift is normal. This is due to the rubber diaphragms which are stretched by the internal springs. After a few operations, the instrument will settle into its normal operating condition. It is recommended that, under these circumstances, instruments should be exercised by alternately applying zero and full scale signals several times. Zero calibration should then be carried out.

Adjust zero control Nr.2 (anti-clockwise) to give minimum required output pressure.

Adjust range control Nr.3 (anti-clockwise) to give maximum required output pressure.

Note : Reverse acting operation

About 20 turns of the zero screw may be required to reset the zero point.

TYPICAL INSTALLATION

