

**“ADCATROL” TEMPERATURE REGULATORS  
 SELF ACTING - NON BALANCED SIMPLE SEAT  
 TR25SS stainless steel valves & T series thermostats**

**DESCRIPTION**

The series TR25 valves are designed for direct acting temperature control systems where the valve closes on temperature rising. They are single seat type in order to guarantee an excellent tightness and are to be coupled with the thermostats model T.205 and T.405. The liquid filling in the thermostat expands with a rise in temperature operating the valve.

The valves are used for controlling the temperature in central heating systems, district heating systems and industrial plants .

Connections are female screwed or flanged.

**MAIN FEATURES**

Single seated, two way, direct action valve.

Leakage less than 0,05% of full Kv

Built-in strainer.

**OPTIONS :**

Valves for cooling applications.

**USE:**

Saturated and superheated steam.

Hot and superheated water.

**AVAILABLE MODELS:**

TR25SS - Steel construction valve body

**SIZES:**

DN 1/4” - DN 3/4” – DN15 - DN 20.

**CONNECTIONS:**

Female screwed ISO7/1Rp(BS 21) .

Flanged EN1092-1 or ANSI.

**CONTROL MODE:**

Proportional

**THERMOSTATS:**

T.205 - 200N (max.closing force)

T.405 - 400N (max.closing force)

**THERMOSTAT RANGES:**

T.205 - 0-60 ; 30-90 and 60-120°C

**CAPILLARY LENGHTS:**

T.405 - 0-120 ; 40-160 °C

**HOW TO SELECT:**

3 m as standard

**VALVE LIMITING CONDITIONS:**

Never size the valve according to the pipe diameter in which it has to be fitted but according to the required actual flow of steam or water. Refer to valve calculation data sheet or consult the factory.

Body design conditions: PN40

40 bar at 120°C

24 bar at 350 °C

Min.working temperature: -10°C

**COOLING UNITS:**

Cooling unit protects the stuffing box of the thermostat. Type K1 is recommended at valve temperatures between 150 and 250°C.

**INSTALLATION:**

Horizontal installation with the thermostat in the vertical position in order to reduce wear. In case of valve temperatures up to 150°C the thermostat may be fitted below or above the valve. In case of valve temperatures between 150 and 250°C a cooling unit type K1 has to be applied with connection downwards. An “Y” strainer should be provided upstream the valve.

See IMI, installation and maintenance instructions.

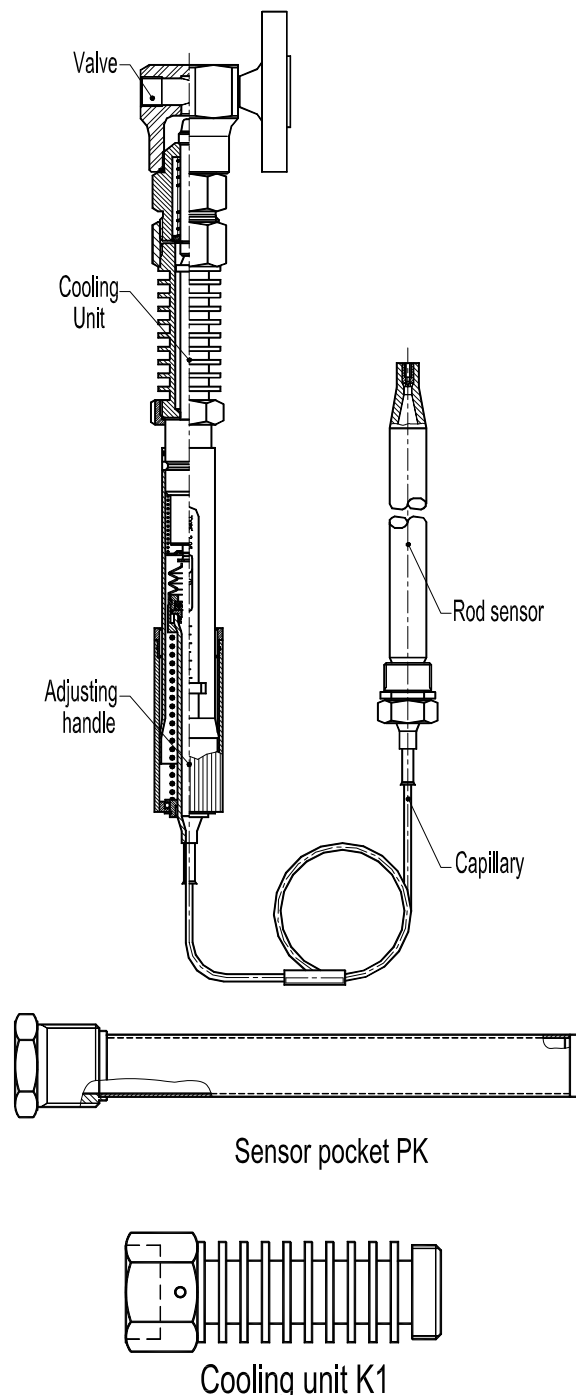

SPECIFICATIONS				
Type	Conn. DN	Opening Ø (mm)	Kvs m <sup>3</sup> /h	Valve stroke
TR25-15/4	15	4	0,2	6
TR25-15/6	15	6	0,45	6
TR25-15/9	15	9	0,95	6
TR25-15/12	15	12	1,7	6
TR25-15	15	15	2,75	6
TR25-20/9	20	9	0,95	6,5
TR25-20/15	20	15	2,75	6,5

MAX. PERMISSIBLE DIF. PRESSURES		
With T.205 Thermostat		
Press. bar	valve Size	Seat Ø (mm)
21	15	4 and 6
13	15	9
9,3	15	12
5,3	15	15
5,3	20	15
With T.405 Thermostat		
40	15	4 and 6
38	15	9
24	15	12
15	15	15
15	20	15

#### PROPORTIONAL BAND

The proportional band is the temperature change required for the valve to move from fully open to fully closed. It depends on the valve stroke and on the thermostat movement per °C, and is calculated as follows:

Proportional band: 
$$\frac{\text{Valve stroke (mm)}}{\text{Thermostat mov. (mm/°C)}}$$

Thermostat movement in mm per °C :

T.205 and T.405 : 0,5 mm / °C

A proportional band in the range 8-13°C is suitable for most applications. A smaller proportional band is not ideal where heat load varies rapidly.

THERMOSTAT DIMENSIONS (mm)					
TYPE	A	B	C	E	Wgt Kg
T.205	305	405	210	22	1,8
T.405	385	525	390	22	2,6

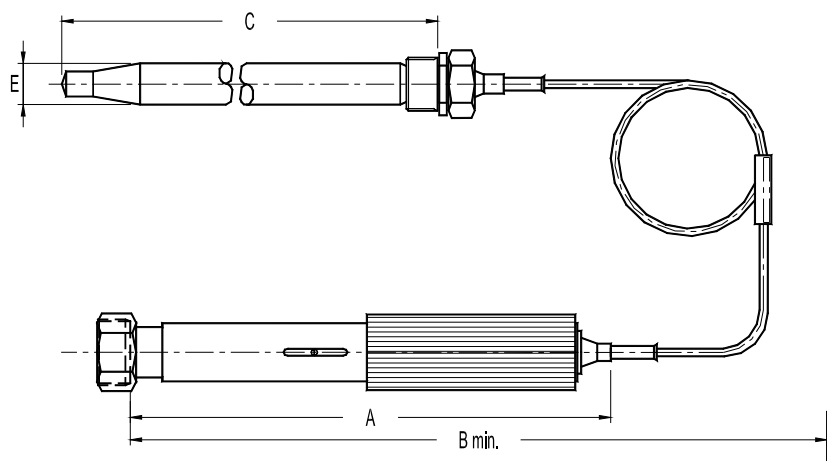

DIMENSIONS (mm)-Screwed						EN1092-1 Flanges		
SIZE DN	A	B	C	F	WGT. Kgs	D	E	WGT. Kgs
1/4"	45	15	93	-	1,1	-	-	-
3/8"	55	15	93	-	1,1	-	-	-
1/2"	70	15	93	70	1,2	130	47,5	2,6
3/4"	70	25	93	70	1,2	130	52,5	3,2

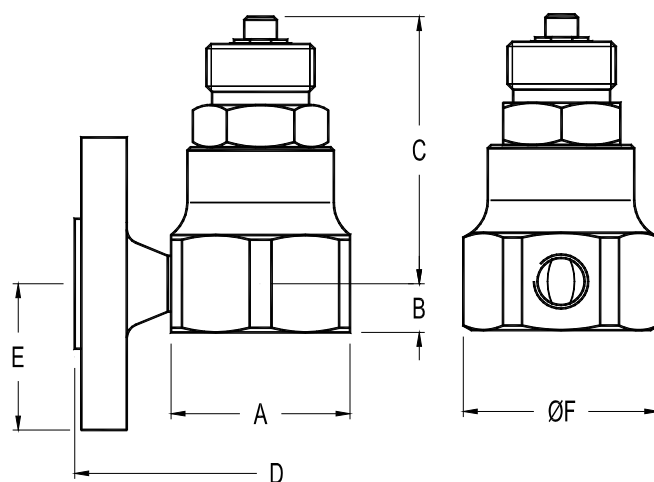

MATERIALS		
POS.	DESIGNATION	MATERIAL
1	Body	AISI316 / 1.4401
2	Bonnet	AISI 304 / 1.4301
3	* Gasket	St.St./Graphite
4	* Valve plug	AISI 316 / 1.4401
6	* Spring	AISI 302 / 1.4300

\*Available spare parts

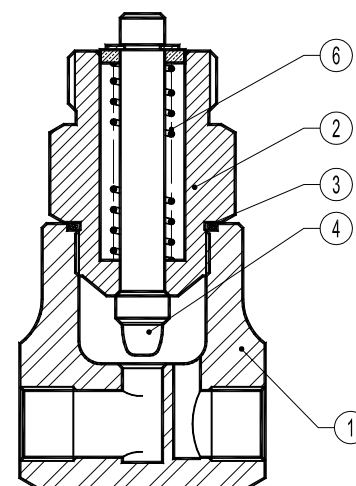

## COOLING UNITS K1

The cooling units are used in connection with control valves and thermostats to protect the stuffing box. At valve temperatures between 150°C and 250°C a cooling unit of type K1 connected downwards should be applied. For higher temperatures as well as for all hot oil systems please consult.

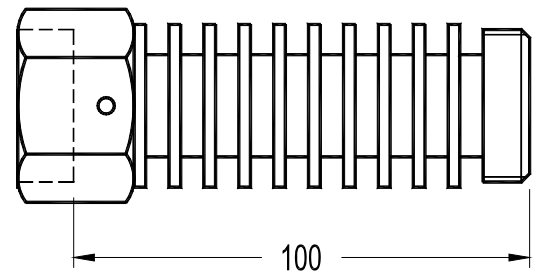

## SENSOR POCKETS PK

Sensor pockets of stainless steel can be supplied to all TR series self-acting thermostats with rod sensors. They are used where it is impossible to empty the system or the tank.

Use of sensor pockets implies delay of heat transfer to the rod sensors and thus a longer reaction time for the controllers. This is to some extent counteracted by filling up the sensor pockets with paste or oil.

## INSTALLATION

The installation site for the sensor pocket is arbitrary when paste is applied. When using oil the sensor pocket must point somewhat downwards.

## MATERIAL

Stainless steel 1.4436

## LIMITING CONDITIONS

40 bar at 120°C  
24 bar at 350°C

POCKET DIMENSIONS (mm)					
TYPE	D	H	L	S	R
PK2	25	9	218	36	1"
PK4	25	10	390	45	1 1/4"

