

FORGED STEEL PIPELINE Y STRAINERS IS 116

DESCRIPTION

IS 116 Y forged steel strainers are applicable to all types of steam, water, oil and air systems.

Their purpose is to protect traps, regulating valves, piping, etc. from dirt which are often times the cause of damage and consequently energy loss of fluid systems.

Connections are female screwed or flanged.

OPTIONS: Different screen aperture sizes
Drain plug or drain valve in strainer cap

USE: Saturated steam, water, oil, air and other compatible fluids.

AVAILABLE MODELS: IS 116

SIZES: DN ½" to DN 2" ; DN 15 to DN50

SCREENS: 0,8 mm aperture

CONNECTIONS: Female screwed ISO 7/1 Rp (BS21)
NPT (ANSI B1.20.1)
Flanged EN 1092-1 or ANSI

INSTALLATION: Horizontal or vertical downstream installation.
See IMI, installation and maintenance instructions.

PMA – Max.allowable pressure 63 bar

TMA – Max.allowable temperature 400 °C

How to order: i.e. IS116 DN 1½" NPT

CE MARKING (PED - European Directive 97/23/EC)

PN 63	Category
DN 15 to DN 32	SEP - art. 3, paragraph3
DN 40-50	1 (CE Marked)

DIMENSIONS (mm)-Screwed					EN 1092-1 Flanges	
SIZE DN	A	B	C	WGT. Kgs	A	WGT. Kgs
15	90	60	105	1	150	2,6
20	110	75	140	1,2	170	3,5
25	130	93	155	2	200	4,6
32	160	120	195	4,5	240	8,3
40	160	120	195	4,5	240	9,5
50	160	145	280	6	245	12

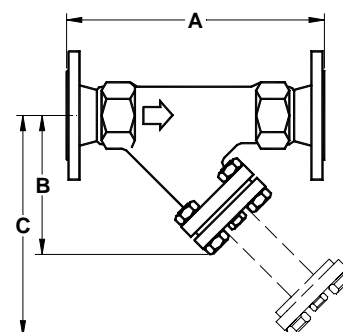
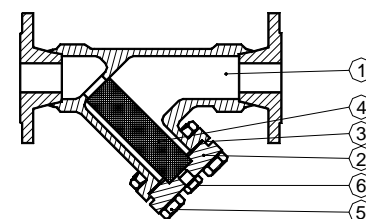
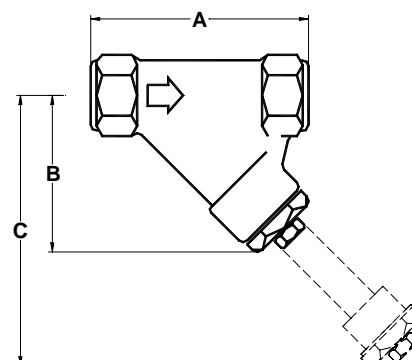
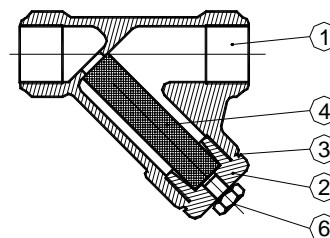

MATERIALS		
POS. Nr.	DESIGNATION	MATERIAL
1	Body	ASTM A105 / 1.0432
2	Cap	ASTM A105 / 1.0432
3	* Gasket	St. Steel / Graphite
4	* Strainer screen	AISI304 / 1.4301
5	Bolts	ASTM A193 B7 / A194 2H
6	Drain plug	ASTM A105 / 1.0432

* Available spare parts (Bolted cover, DN2" only)