

## PRESSURE OPERATED PUMP ADCAMAT PPO-14

### DESCRIPTION

The ADCAMAT PPO14 (Pressure Operated Pump) fabricated carbon steel (stainless steel on request) is recommended in the transfer of high-temperature liquids such as condensate, oils and other liquids to a higher elevation or pressure.

The pump starts when there is something to pump and stops when there isn't.

Under certain conditions, it can drain a closed vessel under vacuum or pressure.

The pump can be operated by steam, compressed air or gas and can be used for lifting any kind of non-corrosive liquids.

Connections are flanged or female screwed (with screwed flanges).

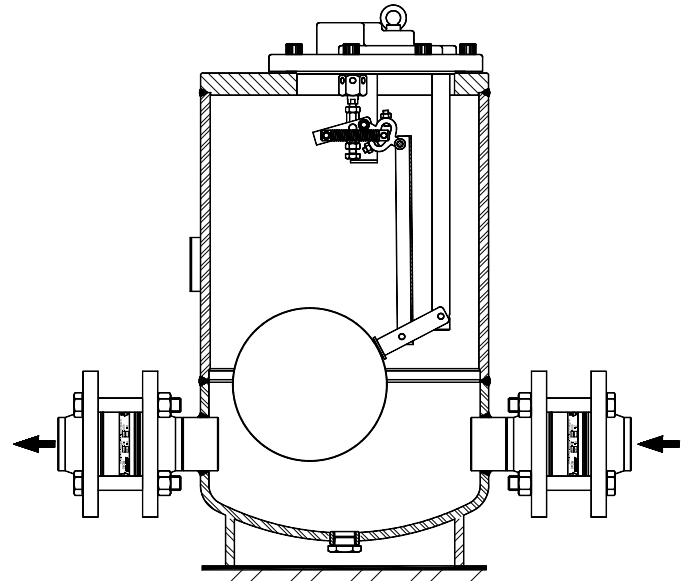

### FUNCTION

Liquid flows by gravity into the pump through an inlet check valve lifting a float which, at the upper limit of its travel, opens the supply valve which allows steam or compressed air to enter the pump body. Pressure in the pump builds up until just sufficient to overcome back pressure.

The pressurized liquid opens the outlet check valve and discharge commences. When the float reaches the minimum lower level it closes the steam or compressed air supply valve and opens the vent, allowing the liquid to fill the pump again.

As the amount of liquid discharged at each stroke is known, the total volume passed during a given period can be calculated by counting the number of strokes during that period. For this purpose a special counter is available which screws into a tapped connection on the top cover of the pump. This counter records the number of pumping strokes thus enabling the pump to function as a reliable flow meter.

**MAIN FEATURES :** Non-electric requirements.

**OPTIONS:** Stainless steel construction.  
Level gauge.  
Stroke counter.

**USE :** To lift condensate or hot and cold liquids.

**AVAILABLE MODELS :** ADCAMAT PPO-14S - carbon steel construction.  
ADCAMAT PPO-14SS - Stainless steel construction (Carbon steel version is sandblasted, metallized and black painted).

**SIZES :** DN 25; DN 40 ; DN 50 .

**CONNECTIONS :** Flanged EN1092-1 PN16. Special flanges upon request. Female screwed ISO 7/1 Rp (BS21).

**INSTALLATION :** Horizontal installation.  
See IMI installation and maintenance instructions.

**MOTIVE GAS :** Steam or compressed air.

LIMITING CONDITIONS		
	Press. bar	Temp. °C
PN16	16	120
	14	198
	13	250
ANSI Cl.150	16	120
	14	198

Minimum operating temp.: -10°C

Design code: AD-Merkblatt

### CE Marking :

This product has been designed for use on water, steam, air and other gases which are in Group 2 of the PED - European Pressure Equipment Directive 97/23/EC and it complies with those requirements. All the sizes fall within category 2. The product carries the CE mark.

**APPLICATION LIMITS**

Minimum density	0,80 kg/dm <sup>3</sup>
Maximum viscosity	5° Engler
Maximum motive pressure	10 bar
Minimum motive pressure	0,5 bar
Pump discharge per cycle DN25 to DN50	16 l

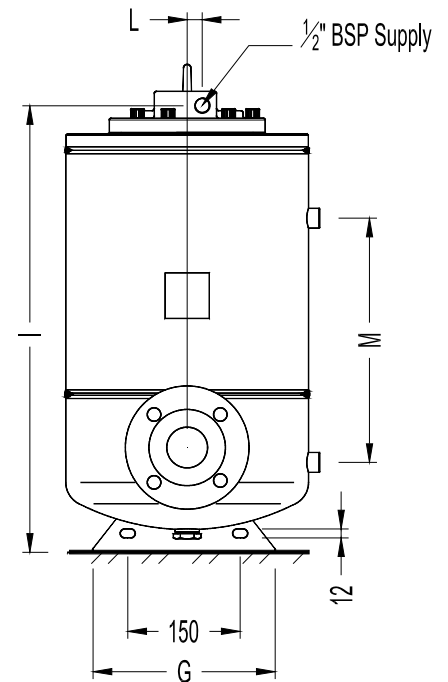
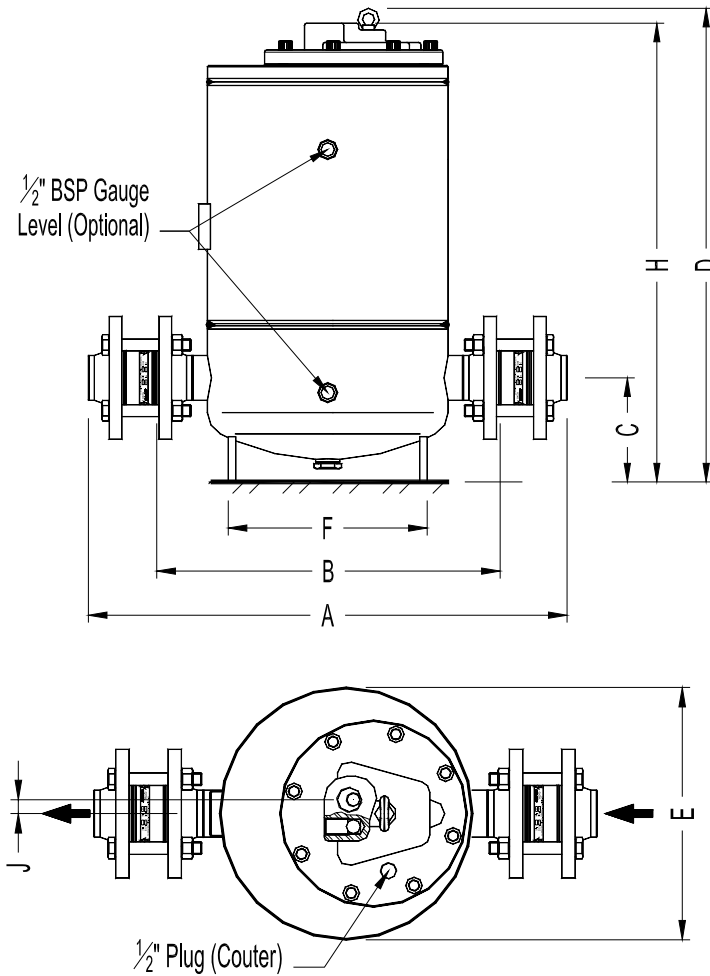

**DIMENSIONS (mm)**

DN	A *	B	C	D	E	F	G	H	I	J	L	M	Weight Kgs	VOL. dm <sup>3</sup>
25	578	444	140	640	323	268	250	617	598	17	18	327	75	32,2
40	615	454	140	640	323	268	250	617	598	17	18	327	72	32,3
50	644	460	140	640	323	268	250	617	598	17	18	327	66	32,5

\* A - with welding neck EN 1092-1 flanges.

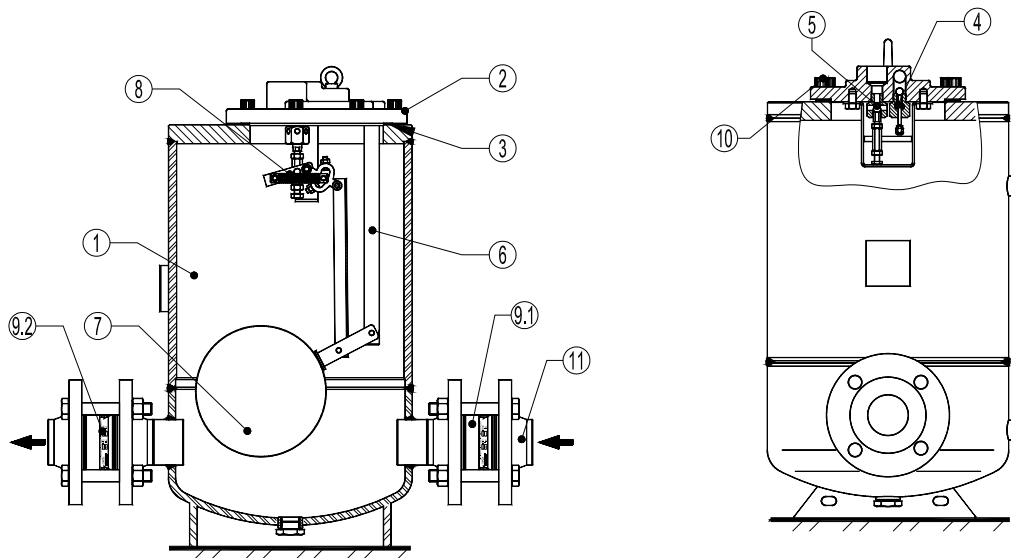

MATERIALS			
POS.	DESIGNATION	MATERIAL - PPO14S	MATERIAL - PPO14SS
1	PUMP BODY	P265GH / 1.0425 ; P235GH / 1.0345 ; S235JR / 1.0038	AISI316 / 1.4401 ; AISI304 / 1.4301
2	COVER	GJS400-15 / 0.7040	AISI316 / 1.4401 ; AISI304 / 1.4301
3	*COVER GASKET	NON ASBESTOS	NON ASBESTOS
4	*INLETVALVE/SEAT ASSY.	STAINLESS STEEL	STAINLESS STEEL
5	*EXHAUST VALVE/SEAT ASSY.	STAINLESS STEEL	STAINLESS STEEL
6	INTERNAL MECHANISM	STAINLESS STEEL	STAINLESS STEEL
7	*FLOAT	STAINLESS STEEL	STAINLESS STEEL
8	*SPRING ASSY.(2PCS)	INCONEL	INCONEL
9.1	*RD40 INLET CHECK VALVE	CF8M / 1.4408	CF8M / 1.4408
9.2	*RD40 OUTLET CHECK VALVE	CF8M / 1.4408	CF8M / 1.4408
10	BOLTS	STEEL 8.8	A2 - 70
11	**PN16 EN 1092-1 FLANGES	P250GH / 1.0460	AISI316 / 1.4401

\* Available spare parts

\*\* Welding neck DIN flanges. Threaded flanges on request.

**Stroke counter :**

Available on request, it can be screwed directly into the top cover of the pump or above the pump through a 1/2" size pipe for easier reading (max. 1m).

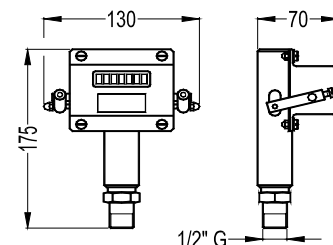

### THREADED PUMP DN 2" – ASSEMBLING POSSIBILITIES

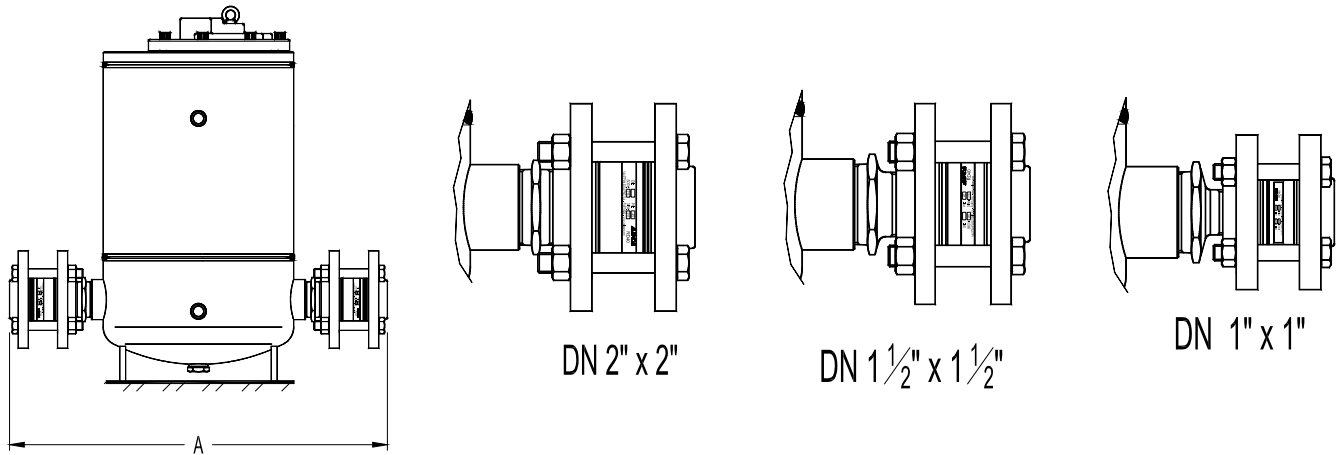

**THREADED PUMP WITH THREADED COUNTER FLANGES - DIMENSIONS (mm)**

PUMP SIZE	A *		
	EN PN16/40	ANSI 150 lbs	ANSI 300 lbs
DN1" x 1"	595	574	593
DN1 1/2" x 1 1/2"	621	601	617
DN2" x 2"	641	624	640

\* Consult factory for certified dimensions.

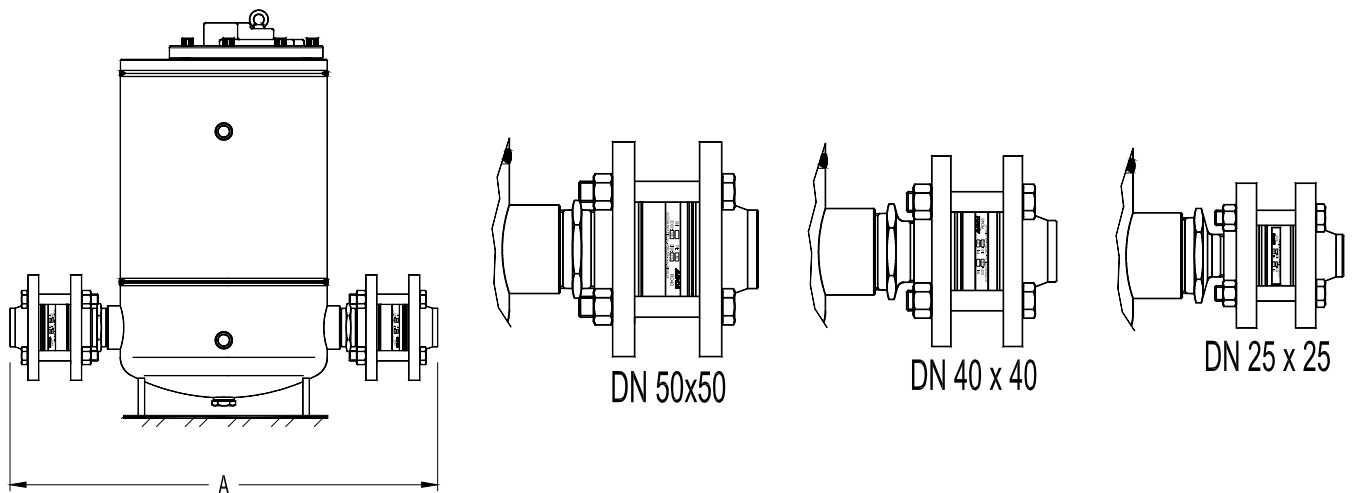

**THREADED PUMP AND WELDING NECK COUNTER FLANGES - DIMENSIONS (m)**

PUMP SIZE	A *		
	EN PN16/40	ANSI 150 lbs	ANSI 300 lbs
DN25 x 25	619	650	663
DN40 x 40	647	681	694
DN50 x 50	669	700	713

\* Consult factory for certified dimensions.