

PACKAGED ADCAMAT AUTOMATIC PUMP (SUITABLE FOR STEAM SUPPLY) POPK-S

DESCRIPTION

The POP-K packaged pump units can be used to lift or displace hot condensate and other liquids even in hazardous areas.

A POP-K packaged unit comprises an Adcamat pump, a vented receiver and all auxiliary items, compactly mounted on a metal frame piped and ready for connection.

Packaged units save time, work and site costs. In addition they ensure that installation of the pump is correct in every detail.

Two or more units can be connected in parallel to cope with flow rates beyond the capacity of a single pump.

Units operating with compressed air are also available.

For operating conditions and pumping capacity, please refer to information sheet IS 9.101 E and IS 9.105 E.

How to order : i.e. ADCAMAT POPK-S DN 40

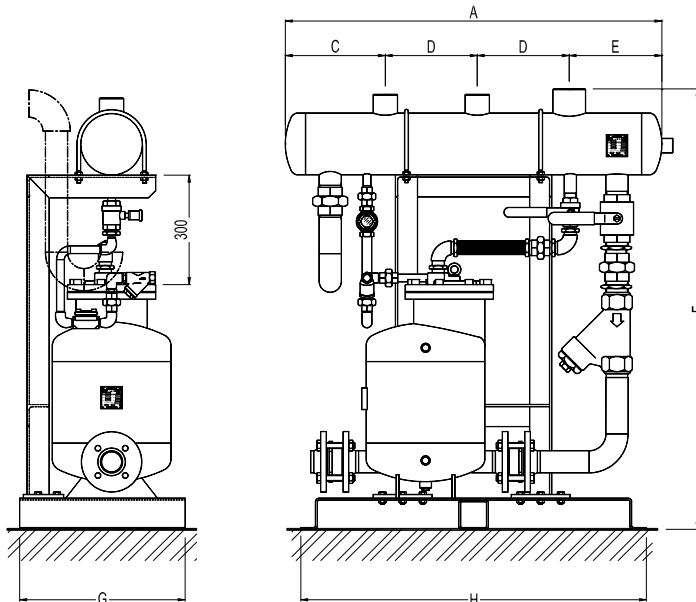
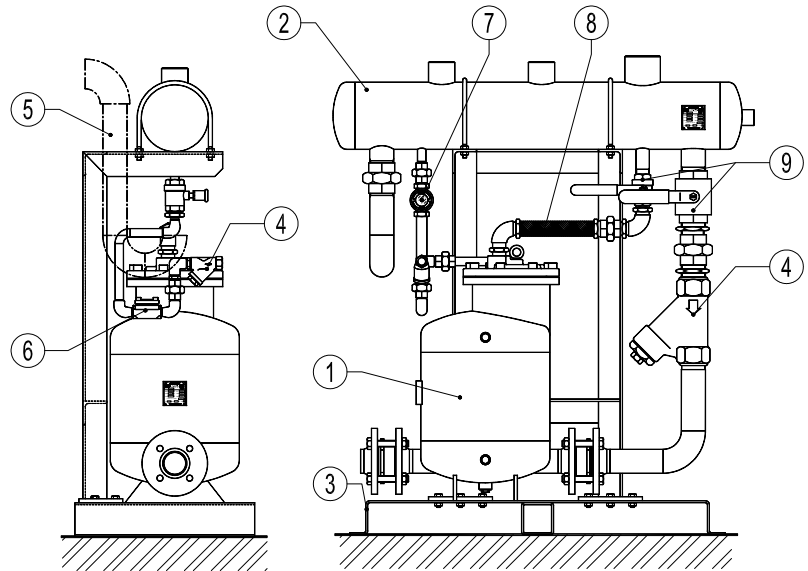

MATERIALS	
POS.	DESIGNATION
1	Pump
2	Receiver
3	Metal frame
4	IS 16 Strainer
5	Overflow
6	TH21 Steam trap
7	SW12 Sight glass
8	Flexible hose
9	Ball valves

LIMITING CONDITIONS:

Receiver – Max. operating pressure : 0,5 bar

Pump: See IS 9.101 E

CONNECTIONS:

All connections are screwed except the pump connections which are flanged EN 1092-1 PN16.

Threaded flanges available on request.

DIMENSIONS (mm)								
DN	A	C	D	E	F	G	H	Wgt. Kgs
25	990	255	250	235	1210	450	940	145
40	1090	305	250	285	1210	450	940	154
50	1120	320	250	296	1260	450	940	188
80x50	1140	330	250	310	1330	535	1040	230

STROKE COUNTER::

Available on request, it can be screwed directly into the top cover of the pump or above the pump through a 1/2" size pipe for easier reading (max.1m).

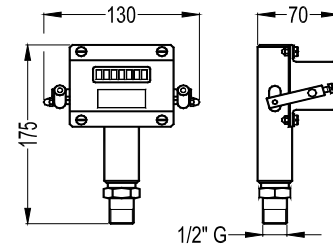

Condensate recovery - open system.

The pump removes high temperature condensate without cavitation problems.

WARNING : Vent line must be unrestricted and self draining to the receiver.

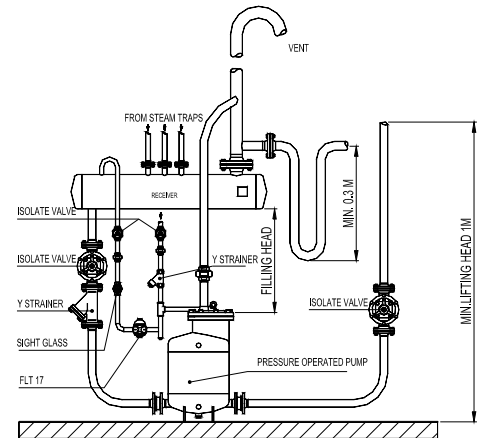

Removal of condensate under pressure with POP pump and steam trap combination. When the steam pressure is sufficient to overcome back pressure the trap operates.

If the pressure decrease than the pressure operated pump start to operate removing the condensate by pumping through the float steam trap.

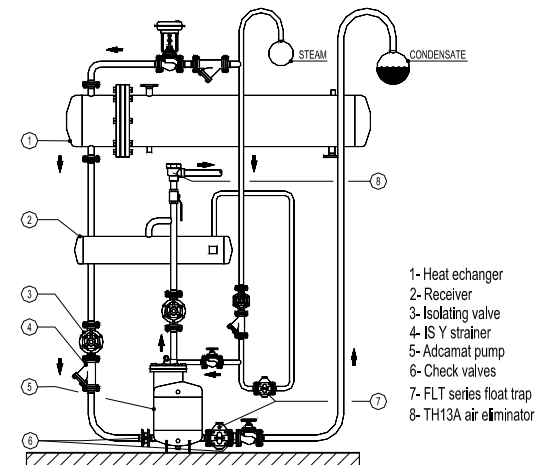

Drainage of a single unit under vacuum (max.0,2 bar abs).

Head H1 must range between 1 and 2 m. The lift H must be the minimum possible but never less than 1 m (otherwise siphon is required as H2).

Use steam as operating medium (max. pressure 2-3 bar).

