

DIRECT STEAM INJECTION HUMIDIFIERS DSH Series

DESCRIPTION

The DSH direct steam injector humidifiers assure highly efficient steam release into the air stream. Each humidifier is designed for your specific capacity, steam pressure and duct width requirements. Single and multiple injection tube units are available to meet the most demanding applications.

High quality control valves and actuators assure accurate response and metering of steam flow, and, we can usually supply the system with your preference valve/actuator combination or we may factory mount them for you.

Connections are female screwed or flanged.

PRINCIPLE OF OPERATION

Single tube and multiple tube humidifiers operate with the same basic design. The steam enters the humidifier separator through the strainer. Separation of the steam and condensate is achieved by the action of our S25 centrifugal separator (special version). Inside the separator, the combination of steam and condensate is directed into the drain baffle and condensate then drains to the bottom of the separator and is removed from the system by a float and thermostatic steam trap.

The steam, free of condensate, then flows out the separator to the injection tube. The steam connection to the outer jacket is recommended to be directly from the steam system in case of multiple tube design and can be taken from the top of the separator in case of single tube design.

MAIN FEATURES

Complete stainless steel injection tube and separator construction.

Quiet operation.

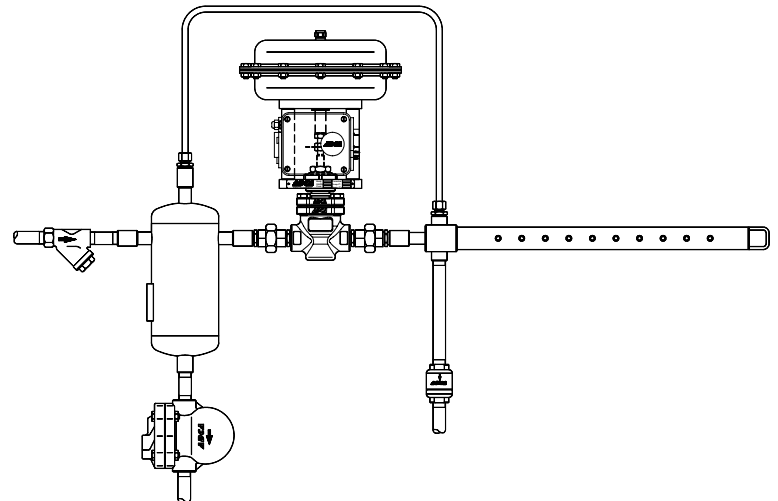

Single tube design

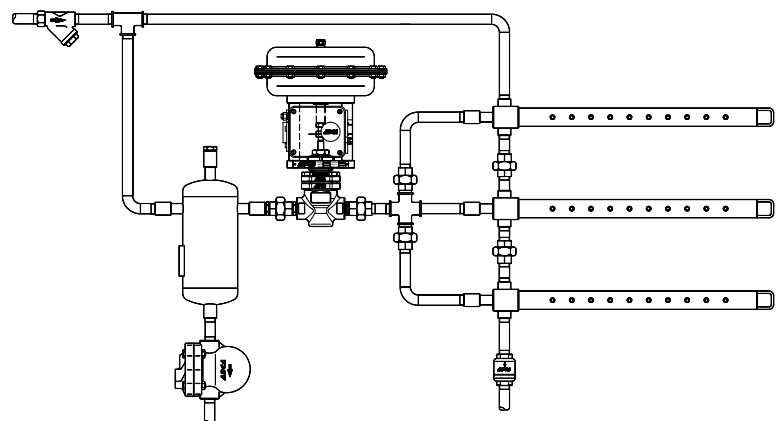

Multiple tube design

OPTIONS:	Single or multiple tube systems
ACCESSORIES:	Steam traps and strainer.
USE :	Saturated steam .
AVAILABLE MODELS :	DSH15-10 ; DSH20-20; DSH25-20 ; DSH 40-30.
SIZES :	DN 1/2" to DN 11/2"
CONNECTIONS :	Female screwed ISO 7/1 Rp (BS21). Flanged connections upon request.
INSTALLATION :	Horizontal installation in horizontal or vertical air ducts. See IMI installation and maintenance instructions.

APPLICATION LIMITS :	Separator body design conditions PN 6
	Maximum operating pressure 4 bar
	Maximum operating temperature 152 °C

When using multiple tube pipe design, the injection tubes are piped and trapped separately to ensure that the additional resistance created by extra piping does not reduce the steam supply to the humidifier and also to provide extra trap capacity to handle the additional condensate created within the multiple injection tube steam jackets.

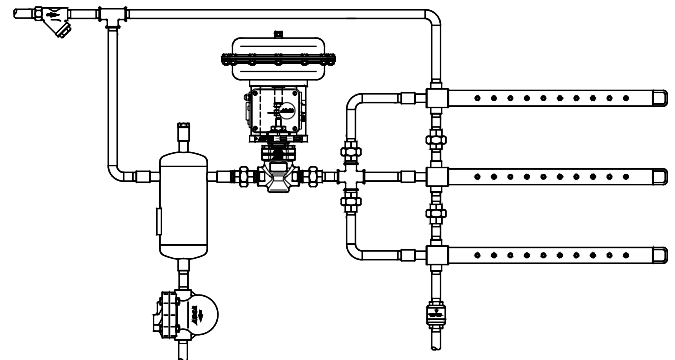

MULTIPLE TUBE HUMIDIFIER	
Recommended Quantity of Tubes	
Duct Height (mm)	Nr. of Tubes
up to 900	2
920 - 1200	3
1220 - 1800	4
1820 - 2400	5
above 2400	6

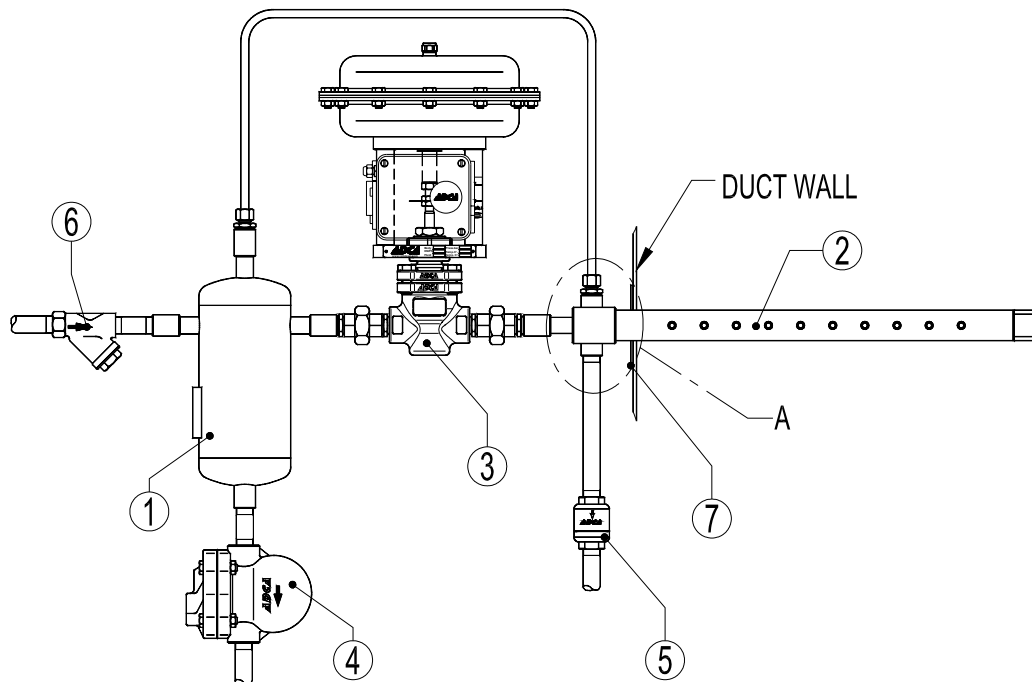

MATERIALS		
POS.	DESIGNATION	MATERIAL
1	STEAM SEPARATOR	STAINLESS STEEL
2	INJECTION TUBE	STAINLESS STEEL
3	* ADCATROL VALVE	ON REQUEST
4	* ADCA FLT STEAM TRAP	ST. STEEL / CAST IRON
5	* ADCA TSS22 STEAM TRAP	STAINLESS STEEL
6	ADCA IS16 STRAINER	CAST IRON

* Available spare parts.

DIMENSIONS

MODEL	DN	A	ØB	C	D	ØE	F	ØG	H	I	ØJ	L	T	U	V	R
DSH15-10	1/2"	230	114	253	145	1/2"		38	76		1/2"	M10	100	50	228	19
DSH20-20	3/4"	230	114	248	150	1/2"	*	51	89	**	3/4"	M10	110	55	100	25,4
DSH25-20	1"	266	140	250	160	3/4"		51	89		3/4"	M10	110	55	100	25,4
DSH40-30	1 1/2"	304	168	365	185	3/4"		76	121		1 1/4"	M10	130	75	120	38,3

* F - Depending from valve selection

** I - Special tube lengths are available, consult factory for details.

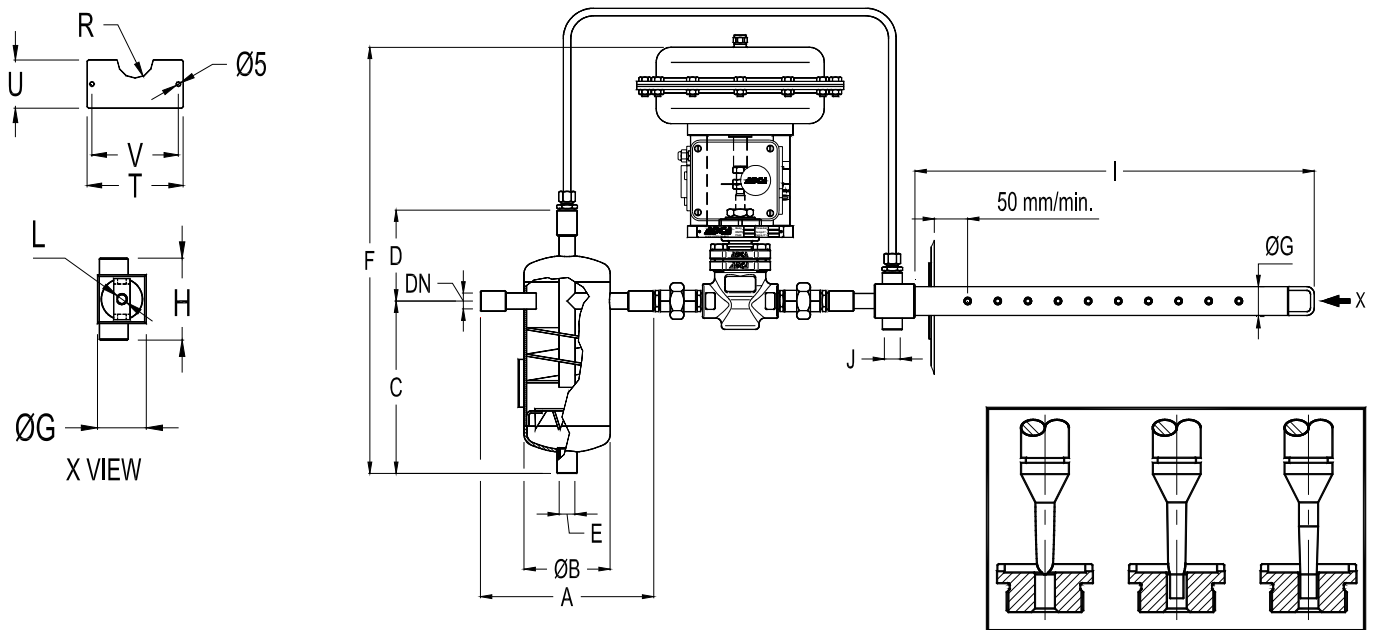
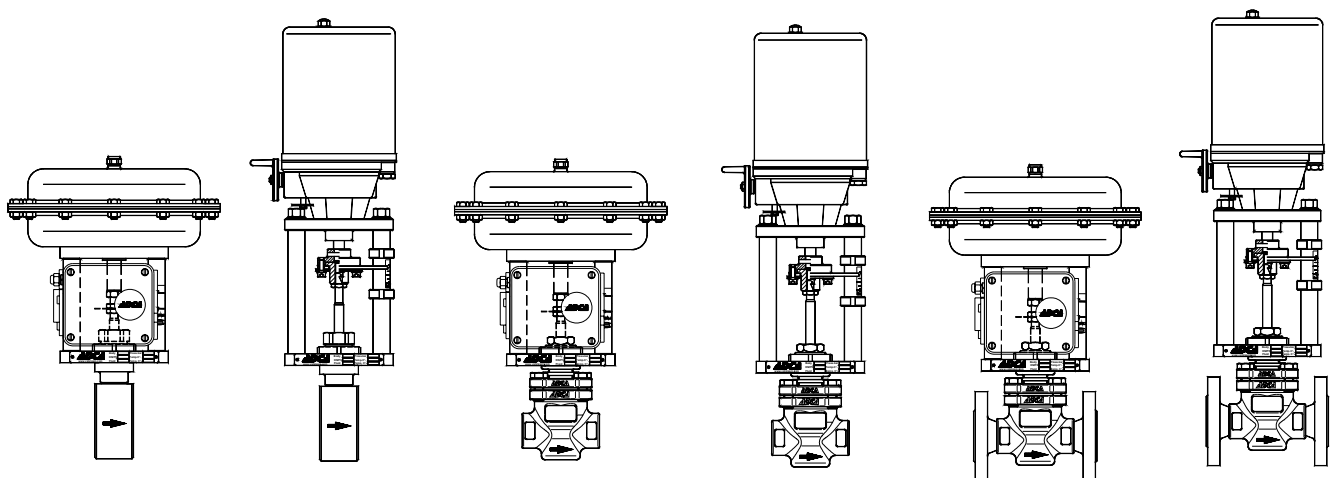

Fig.1

VALVES AND ACTUATORS

Adcatrol line offer a large range of control valve options (Fig.2) for electric or pneumatic fine control, including low flow designs (Fig.1). Please ask for specific documentation according to your selection.



PWV / EWV Wafer type

PV25 / EV25 Threaded

PV25 / EV25 Flanged

Fig.2



SELECTION AND CAPACITY TABLES

TABLE 1 - INJECTION TUBE HUMIDIFIER , SEPARATOR / VALVE STEAM CAPACITY IN KGS / Hr																								
MODEL	VALVE (Kv - DN)	STEAM PRESSURE TO HUMIDIFIER SUPPLY CONNECTION (in barg)																						
		0,14	0,20	0,27	0,35	0,40	0,48	0,55	0,60	0,68	0,75	0,80	0,90	0,95	1,00	1,35	1,70	2,00	2,40	2,70	3,00	3,50	3,75	4,00
	0,09 - 1/2"	0,75	0,85	1	1,2	1,3	1,4	1,5	1,6	1,65	1,75	1,8	1,9	1,95	2	2,3	2,6	2,85	3	3,3	3,5	3,65	3,85	4
	0,19 - 1/2"	1,59	1,9	2,37	2,54	2,81	2,99	3,22	3,45	3,63	3,8	3,9	4	4,4	4,5	4,98	5,9	6,4	6,8	7,3	7,7	8,2	8,6	9
	0,35 - 1/2"	2,9	3,5	4,2	4,5	5	5,5	5,9	6,4	6,8	6,8	7,3	7,3	7,7	8,2	9	10,5	11,4	12,3	13,2	14	15	15,5	16,5
	0,65 - 1/2"	5,5	6,5	7,7	8,6	9,5	10,5	11	11,8	12,5	12,7	13,6	14	14,5	15	17,3	19,5	21,3	22,7	24,5	25,8	27,2	28,6	30
DSH 15	0,80 - 1/2"	6,8	8,2	9,5	10,9	12,3	13,2	14	15	15,4	16,3	17,3	17,7	18,2	19	21,8	24,5	26,7	29	30,8	32,7	34,5	36,3	38
	1,20 - 1/2"	9,5	10,9	13,2	15	16,3	17,7	19	20	21,3	22,3	23,2	24	25	25,8	30	33,5	36,3	39,5	42,2	45	47,2	49,5	51,7
	1,50 - 1/2"	12,7	15	18,2	20	22,3	23,5	25,4	27,2	28,6	30	31,3	32,6	33,5	34,5	40	44,9	48,5	52,6	56,3	59,8	63	66,3	69,5
	1,90 - 1/2"	15,9	18,6	22,7	25	27,7	30	32,2	34	35,8	37,2	39	40,8	42	43	50,3	55,8	60,8	66,3	70,8	74,8	78,9	83	87
	2,80 - 1/2"	23,5	27,7	33	37,2	40,8	43,5	47,2	49,9	52,6	54,8	57,6	59,8	62,2	63,5	74	82	89,8	97	103,8	110,7	116,6	122,5	128
	3,80 - 1/2"	31,7	37,6	44,5	50	54,8	59	64	67,5	71,2	74	78	80,8	83,9	86	100	110,6	120,7	131,5	140,6	148,8	156,5	164,7	172,8
	4,75 - 3/4"	38,5	47	55,8	62,5	68	73	79,8	84,4	88,9	92,5	96,6	100,7	104,8	107	124,8	138,4	151	163	174,6	185	195	204	214
DSH 20	5,3 - 3/4"	43,5	53	62,5	70,3	76,6	82,5	89,8	95	99,8	104,4	108,9	113,4	117,5	120	140,5	155,6	168,8	182,8	196,9	208	220	230,5	240
	6,5 - 3/4"	52,6	64,5	75,3	84,4	92,5	99,8	108	115	120	125,6	131	137	141,5	145	170	187	204	221	238	251,8	265,4	278,5	290,4
	7,00 - 1"	55,8	70,3	81,7	92,5	101,2	108,9	118,4	124,8	131,6	137,5	142	148,8	155	158,4	185	201	221,3	240	258,5	273,5	288	303	319
DSH 25	8,60 - 1"	68	85,8	99,8	112,5	123	133	143,8	152	160,5	167,8	172,4	181,5	187,8	191,8	225,5	245	267	293	315	331,4	349	367,5	385,5
	10,30 - 1"	81,7	103,5	120	134,3	147,9	159	172	182	191,5	200	207	211	223	230	270	294	324	351	375	397	-	-	-
DSH 40	17,20 - 1 1/4"	136	170	199	224	245	264	286	302	318	334	340	350	369	378	449	481	535	580	624	662	-	-	-
	24,00 - 1 1/2"	272	326	395	444	490	505	562	596	631	660	671	693	722	751	890	944	1052	1143	1234	1317	-	-	-

TABLE 2 - INJECTION TUBE STEAM CAPACITY IN KGS/ HR																							
MODEL	STEAM PRESSURE TO HUMIDIFIER SUPPLY CONNECTION (in barg)																						
	0,14	0,20	0,27	0,35	0,40	0,48	0,55	0,60	0,68	0,75	0,80	0,90	0,95	1,00	1,35	1,70	2,00	2,40	2,70	3,00	3,50	3,75	4,00
10	43	52	61	69	76	82	88	95	102	108	114	120	125	131	137	143	149	155	160	166	172	178	184
20	84	100	121	140	154	168	182	197	210	222	235	248	260	273	285	298	311	324	337	349	362	375	387
30	151	189	222	260	300	309	333	357	381	405	429	453	477	501	525	549	573	597	621	645	670	693	718
-																							

Model Nomenclature:

DSH15 . 10 . 200 . 1

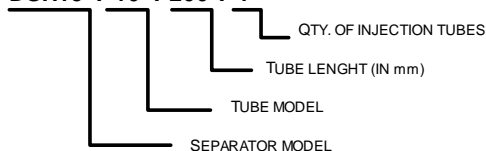

Example (simple tube) :

Total humidification load 36Kg/h at 1,35 bar
 Number of injection tubes required : 1
 Duct width : 200 mm
 From Table 1 you will see that a Model DSH 15 separator is required with valve Kv = 1,5. From Table 2 you will see that a Model 10 injection tube , at 1,35 bar, can emit the required tube humidification load.
 The correct model code would be : DSH15.10.200.1
 Control valve code if supplied, should be according to the selected model.

Example (multiple tube) :

Total humidification load 180Kg/h at 1,7 bar
 Number of injection tubes required : 2
 Injection tube humidification capacity : 90 Kg/h
 Duct width : 1200 mm
 From Table 1 you will see that a Model DSH20 separator is required with valve Kv=6,5.
 From table 2 you will see that a Model 10 injection tube , at 1,7 bar, can emit the required tube humidification load.
 The correct model