

ADCATHERM FLASH CONDENSING HEADS FCD

DESCRIPTION AND OPERATION

The Adca flash condensing heads are designed to promote energy efficiency on new or existing systems.

Mixing the flash steam with the boiler water make up allows the energy within the flash steam to be fully absorbed into the water and therefore reduces energy waste that normally occurs from the discharge of flash steam through a vent.

The main advantages over some traditional systems are that it is possible to make most of the piping connections in a single and compact mixing unit and that a greater quantity of heat recovery can be achieved.

This mixing unit includes the following fluid connections:

- Cold water make up
- Condensate return
- Re-circulating feedwater
- Vacuum breaker and vent connection
- Optional connections for flash steam from a TDS (Total Dissolved Solids) heat recovery system.

The mixing unit includes the necessary baffles, spray nozzle, water injector pipe, etc in order to guarantee the high mixing energy efficiency. The water is finally mixed in the vessel as it passes through an immersion tube which ensures a quiet operation.

The feedwater is re-circulated using a low power re-circulating pump which will improve thermal efficiency by reducing the temperature stratification.

Additional equipment can be used to improve energy efficiency and accurate control. Adcatrol control valves, steam injectors, exhaust heads and many other items of equipment are available from an ADCA supplier. Since each plant has particular requirements we suggest that a local Adca distributor is contacted for layout discussion and equipment selection.

MAIN FEATURES

- Prevents energy wasting
- Easy to install
- Stainless steel construction
- Reduces the flow of flash steam from the vessel venting pipe.

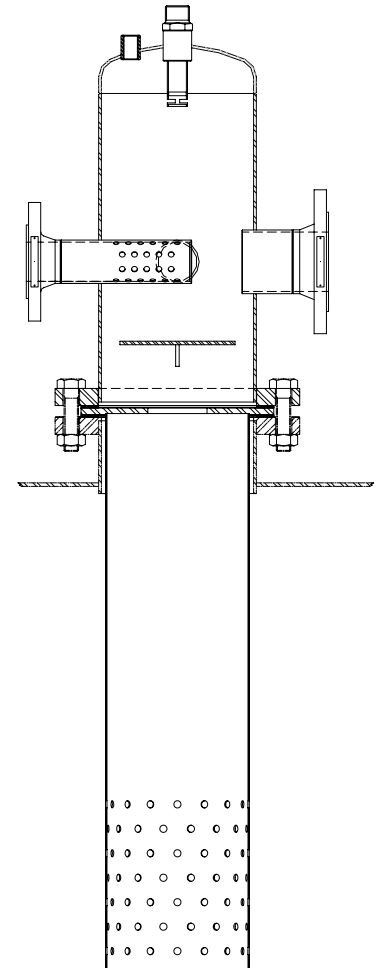

OPTIONS: Complete system including all the necessary equipments

USE: On boiler water feed tanks .

AVAILABLE MODELS: FCD150,200,250,300 and 400.

CONNECTIONS: Female screwed.
Flanged DIN or ANSI.
Different connections on request.

INSTALLATION: Vertical installation, on the top of the vessel.
Connections according to the supplied drawing.

SELECTION TABLE					
Max. Steam Generation (kgs/h)	5000	10000	20000	30000	50000
Model	FCD150	FCD200	FCD250	FCD300	FCD400

The length of immersion tube to be defined according to the vessel design.

DIMENSIONS

Model	A	B	C	D1	D2	D3*	E**	G1	G2	WEIGHT
FCD150	150	484	175	50	25	40	195	1"	1/2"	***
FCD200	200	522	200	80	32	50	195	1"	1/2"	***
FCD250	250	557	220	100	50	80	195	1"	1/2"	***
FCD300	300	617	250	100/150	65	100	195	1"	1/2"	***
FCD400	400	680	290	150	80	100	195	1"	1/2"	***

*Optional ; ** Dimensions on request (Standard: 950,1200,1600,2100mm); *** Weight to be confirmed .

MATERIALS

POS.	DESIGNATION	Material
1	Mixing unit	St.Steel
2	Immersion tube	St.Steel
3	Spray nozzle	St.Steel
4	Gaskets	C 4430
5	Condensate return	St.Steel
6	Coldwater make-up	St.Steel
7	Flash steam(option)	St.Steel
8	Airvent conn.	St.Steel
8	Vaccum breaker conn.	St.Steel

