

STEAM DISTRIBUTION MANIFOLD MAS

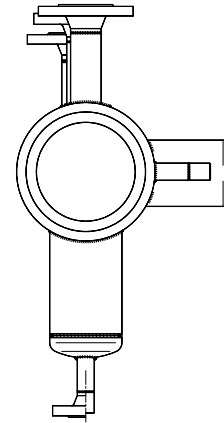
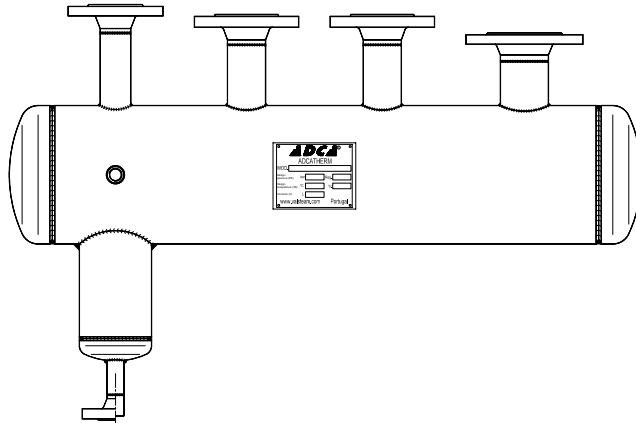

DESCRIPTION

MAS series steam distribution manifolds place the steam supply valves in one location, providing cost savings and easy control of different steam lines.

The drain connection with automatic steam trap, discharge any condensate formed, providing high quality dry steam.

Connections are flanged or threaded.

MAIN FEATURES

Several installation possibilities

Reduced field assembly costs by means of prefabrication.

OPTIONS: Complete units including valves , pressure gauge and steam trap station
Different designs

USE: Saturated or superheated steam
Water, compressed air and other fluids (on request)

AVAILABLE MODELS: MAS-H – Horizontal steam distribution manifold
MAW-H – Horizontal liquid manifold
MAG-H – Horizontal gas manifold

SIZES: DN100 to DN300.

PIPE CONNECTIONS: Flanged EN 1092-1 PN16 and PN40
ANSI Class 150 lbs and Class 300 lbs
Female screwed BSP or NPT on request.

INSTALLATION: Always with the condensate connection pointing downwards.

DESIGN CODE: AD Merkblatt

INQUIRY

INFORMATION: Kind of fluid, maximum operating pressure and temperature
Manifold diameter (dimension B)
Number of connections from left to right using suffix "I" and "O" to identify the inlets and outlets. Example: MAS-H B-168 with 1DN100-I + 2 DN50-O + 1DN40-O
Condensate connection d1
Other relevant information like insulation thickness, instrumentation connections, etc.
Note: In case of order an approval drawing shall be sent before manufacturing

CE Marking

This product have been designed for use on water steam, air and other gases which are in Group 2 of the PED-European Pressure Equipment Directive 97/23/EC and it must comply with those requirements.

The product carries the CE mark when falling in category 1 and above.

Since this is not a standard product which can have different volumes and operation conditions, the conformity assessment has to be carried out case by case.

STANDARD MATERIALS		FLANGE CONNECTIONS			
DESIGNATION	MATERIAL	Rating	SIZE	EN STD.	ANSI STD.
Body	EN10216-2 / P235GH / 1.0325	PN16	* DN15 to DN50	EN 1092-1 PN40	ANSI B16.5 Cl.150 lbs
Heads	EN10028-2 / P265GH / 1.0425	PN16	DN65 to DN300	EN 1092-1 PN16	ANSI B16.5 Cl.150 lbs
Inlet / Outlet pipes	EN10216-2 / P235GH / 1.0325	PN25	DN15 to DN150	EN 1092-1 PN40	ANSI B16.5 Cl.300 lbs
DIN flanges	EN10222-2 / P250GH / 1.0460	PN25	DN200 to DN300	EN 1092-1 PN25	ANSI B16.5 Cl.300 lbs
ANSI flanges	ASTM A105 / 1.0432	PN40	DN15 to DN300	EN 1092-1 PN40	ANSI B16.5 Cl.300 lbs
Sockets	ASTM A105 / 1.0432				
* Internals	EN10025-2 / S235JR / 1.0038				

* Flanges EN 1092-1 PN16 and PN40 from DN15 to DN50 has the same number and size of holes.

EN10204 3.1 certificate available if requested with the order.

* If any.

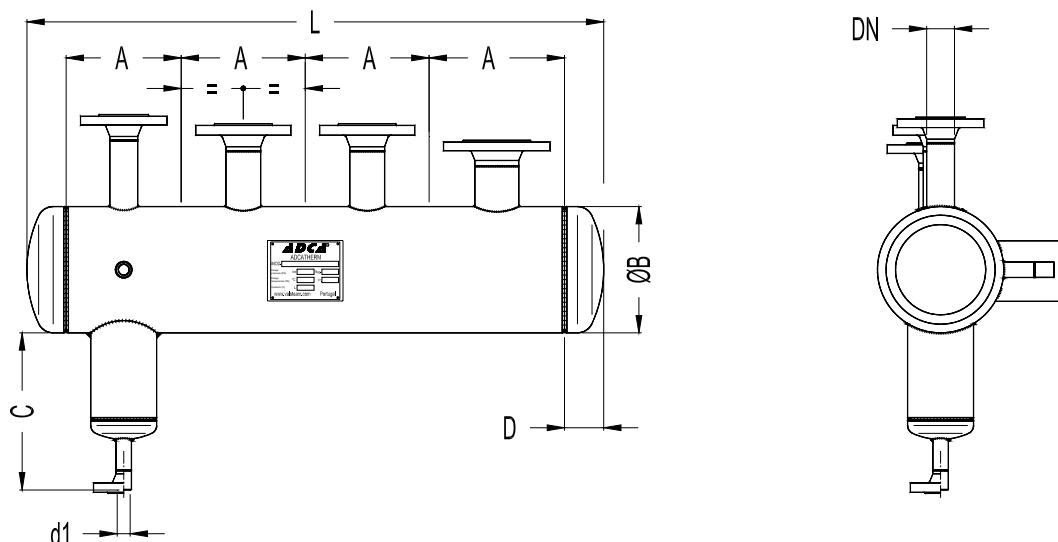

APPROXIMATE DIMENSIONS (mm)														
EN 1092-1 FLANGES														
DN	15	20	25	32	40	50	65	80	100	125	150	200	250	300
A (mm)	145	155	165	190	200	215	235	250	270	300	335	395	455	510

Suggested dimensions for standard EN 1092-1 PN16-40 flanged globe valves.

APPROXIMATE DIMENSIONS (mm)							
STANDARD PIPES							
Ø B	114	140	168	220	275	325	357
D (mm)	40	45	55	70	80	90	105
DN *	65	80	100	150	200	250	300

* Maximum recommended size connection.

TYPICAL INSTALLATIONS

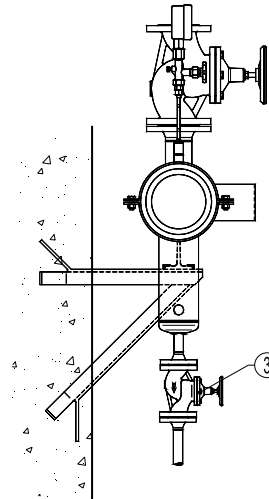
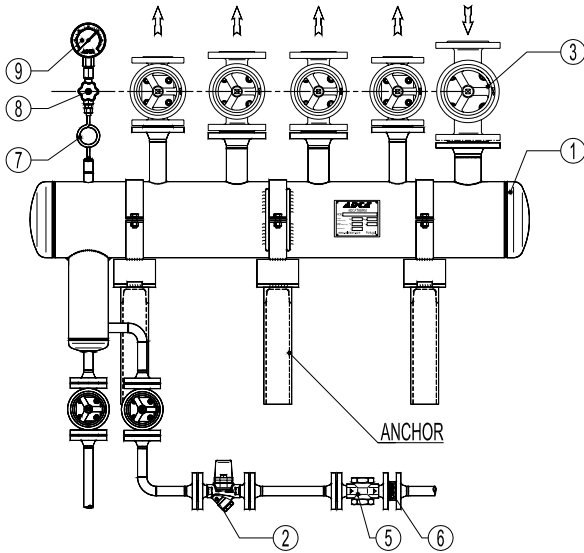

MATERIALS	
Pos. Nr.	REFERENCE
1	MAS-H - Manifold
2	BM32 - Bimetallic steam trap
3	VF16 - Bellow seal valve
5	DW40 - Sight glass
6	RD40 - Check valve
7	GSC-40 Gauge siphon
8	GC-400 - Gauge cock
9	MAN-100 - Pressure gauge

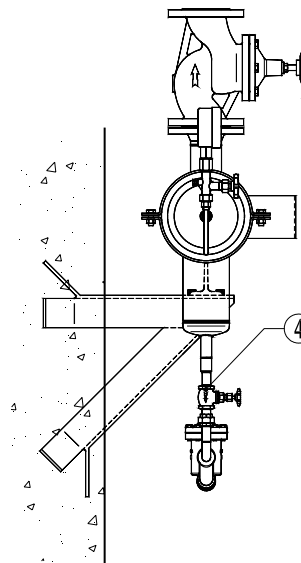
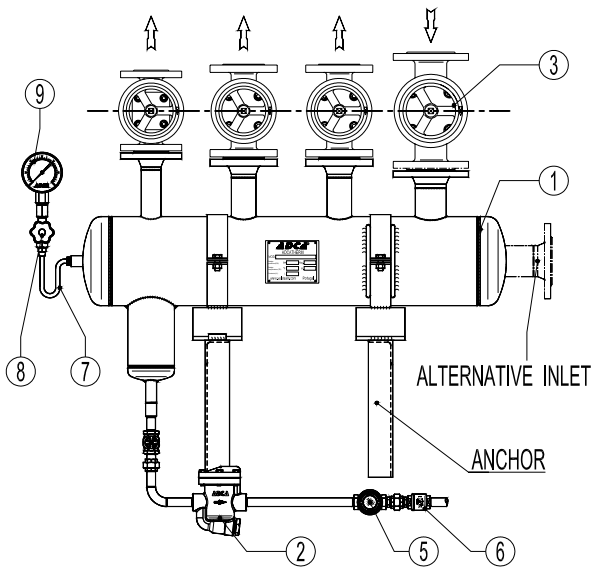

MATERIALS	
Pos. Nr.	REFERENCE
1	MAS-H - Manifold
2	IB12 - Inverted bucket trap
3	VF16 - Bellow seal valve
4	GV32B - Globe valve
5	SW12 - Sight glass
6	RT25 - Check valve
7	GSU40- Gauge siphon
8	GC-400 - Gauge cock
9	MAN-100 - Pressure gauge

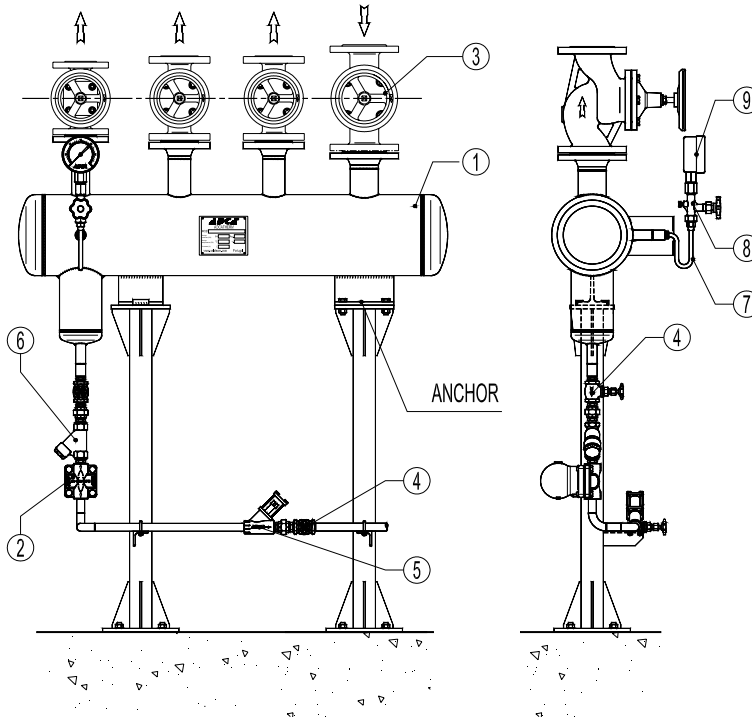

MATERIALS	
Pos. Nr.	REFERENCE
1	MAS-H - Manifold
2	FLT17LC - Float steam trap *
3	VF16 - Bellow seal valve
4	GV32B - Globe valve
5	SCK - Sight checker
6	IS16 - Y strainer
7	GSU40- Gauge siphon
8	GC-400 - Gauge cock
9	MAN-100 - Pressure gauge

* Recommended for low pressure only.

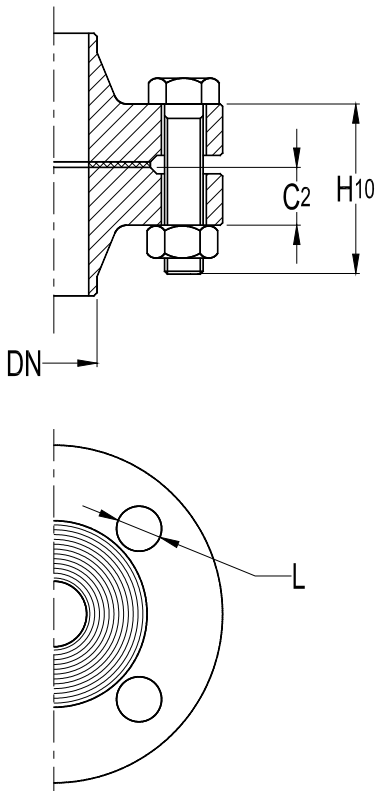

BOLTING DIMENSIONS FOR FLANGES															
DN	EN 1092-1 Type 11 PN16					EN 1092-1 Type 11 PN25					EN 1092-1 Type 11 PN40				
	C2	Ø L	Bolting		H 10	C2	Ø L	Bolting		H 10	C2	Ø L	Bolting		H 10
			Nr.	Size				Nr.	Size				Nr.	Size	
15	16	14	4	M12	50	16	14	4	M12	50	16	14	4	M12	50
20	18	14	4	M12	55	18	14	4	M12	55	18	14	4	M12	55
25	18	14	4	M12	55	18	14	4	M12	55	18	14	4	M12	55
32	18	18	4	M16	55	18	18	4	M16	55	18	18	4	M16	55
40	18	18	4	M16	55	18	18	4	M16	55	18	18	4	M16	55
50	18	18	4	M16	55	20	18	4	M16	60	20	18	4	M16	60
65	18	18	4*	M16	55	22	18	8	M16	65	22	18	8	M16	65
80	20	18	8	M16	60	24	18	8	M16	70	24	18	8	M16	70
100	20	18	8	M16	60	24	22	8	M20	75	26	22	8	M20	75
125	22	18	8	M16	65	26	26	8	M24	80	28	26	8	M24	90
150	22	22	8	M20	70	28	26	8	M24	90	30	26	8	M24	90
200	24	22	12	M20	75	30	26	12	M24	90	36	30	12	M27	110
250	26	26	12	M24	80	32	30	12	M27	100	42	33	12	M30	120
300	28	26	12	M24	90	34	30	16	M27	100	52	33	16	M30	140

* Flange EN 1092-1 DN65 PN16 with 4 holes as standard. Flange with 8 holes upon request.