

ADCATHERM - R Series Tubular Heating Coils (Steam to water)

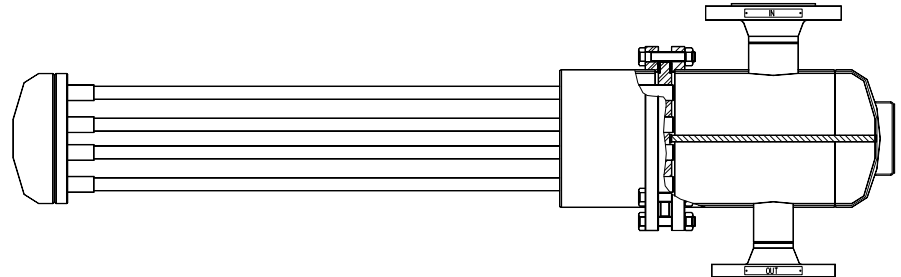
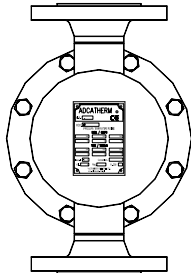

DESCRIPTION

The ADCA-R series steam to water tubular heating coils are shorter and lighter than the alternative tubular heating coils manufactured with smooth pipes. The use of extruded low fin tube, has the advantage that it can improve the external surface and thermal performance.

MAIN FEATURES

Corrosion-resistant stainless steel low finned tube bundle construction.

Straight tubes for easy cleaning.

Floating head at the end of the tube bundle, avoiding tube stresses caused by thermal expansion and contraction.

OPTIONS :

Special designs.

USE :

Steam, water, hot condensate and other fluids compatible with the construction.

AVAILABLE MODELS: R5, R6, R8 and R10

CONNECTIONS : Flanged or screwed, according to EN 1092-1 or ANSI standards.

INSTALLATION: Horizontally on vertical or horizontal vessels.

Steam runs inside the tubes and process water outside.

ORDER

REQUIREMENTS: See inquiry sheet.

CE Marking :

This product has been designed for use on water and steam which are in Group 2 of the PED-European Pressure Equipment Directive 97/23/EC and it complies with those requirements. The product carries the CE mark.

LIMITING CONDITIONS

Rating	Press. bar	Temp. °C	Rating	Press. bar	Temp. °C
PN16	16	120	ANSI Cl.150 lbs	16	120
	14 *	198		14 *	198
	13	250		-	-

*PMO-Max.operating pressure for saturated steam.

Minimum operating temp.: -10°C. Design code: AD-Merkblatt

MATERIALS

DESIGNATION	Material
Tube bundle	AISI316L / 1.4404
Tubesheet	AISI316 / 1.4401
Heads	S235 JRG2 / 1.0038 ; P235GH / 1.0305
Inlet / Outlet pipes	P235GH / 1.0305
EN flanges	P250GH / 1.0460
ANSI Flanges	ASTM A105 / 1.0432
Sockets	ASTM A105 / 1.0432
Supports	S235 JRG2 / 1.0038

EN 10204 3.1 certificate available if requested with the order.

CE MARKING - GROUP 2 GASES CATEGORIES

RATING	MODEL	CAT.
PN16	R5.075 to R5.150	1
	R6.075 to R6.150	1
	R8.075 to R8.150	2
	R10.075 to R10.150	2

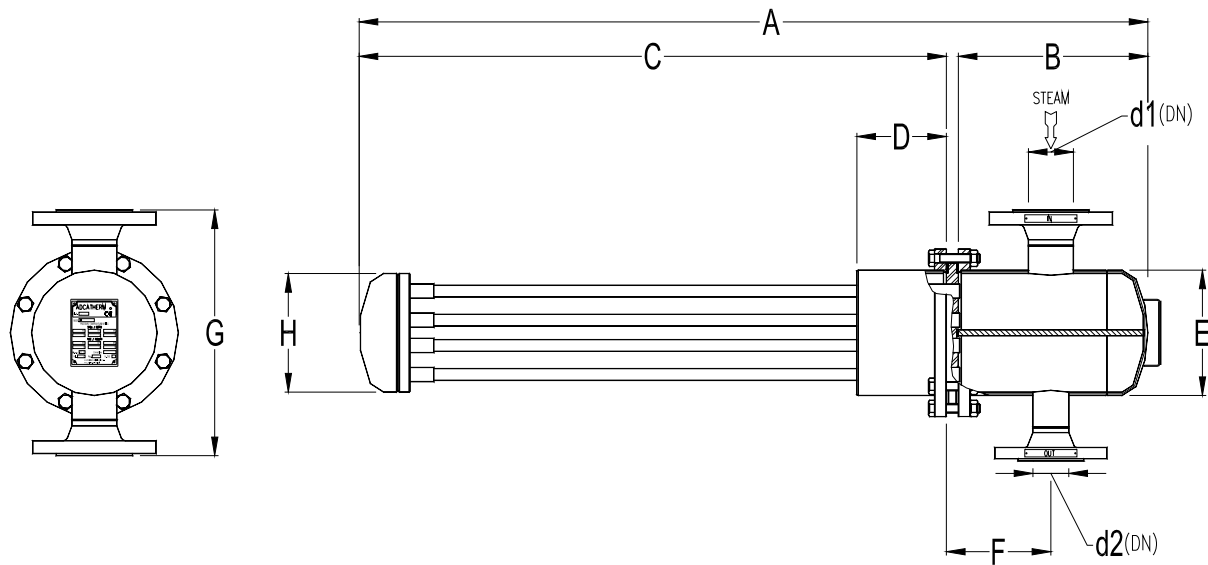

DIMENSIONS

Model	A	B	C	D	E	F	G	H	d1	d2
R5.075	1010	234	762	120	139	145	340	128	40	25
R5.100	1260	234	1012	120	139	145	340	128	40	25
R5.150	1760	234	1512	120	139	145	340	128	40	25
R6.075	1040	254	770	120	168	145	368	157	65	40
R6.100	1290	254	1020	120	168	145	368	157	65	40
R6.150	1790	254	1520	120	168	145	368	157	65	40
R8.075	1060	264	780	130	220	145	420	204	80	50
R8.100	1310	264	1030	130	220	145	420	204	80	50
R8.150	1810	264	1530	130	220	145	420	204	80	50
R10.075	1097	304	775	130	273	145	473	257	80	50
R10.100	1347	304	1025	130	273	145	473	257	80	50
R10.150	1847	304	1525	130	273	145	473	257	80	50

d1 and d2 connections sized according with the flow conditions.

Dimensions subject to change without notice.

Since each coil is built to suit specific plant requirements please consult factory for certified dimensions and weight.

Other sizes and designs can be supplied under request.

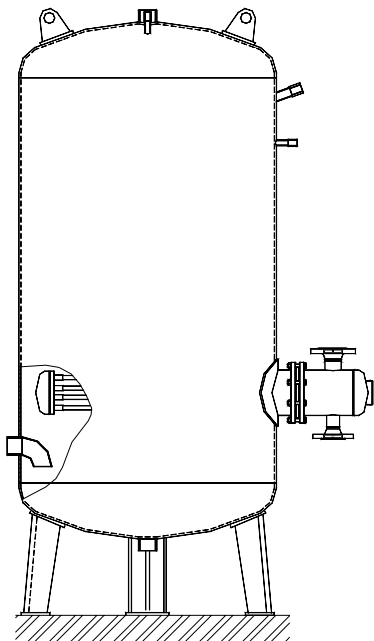

Vertical vessel

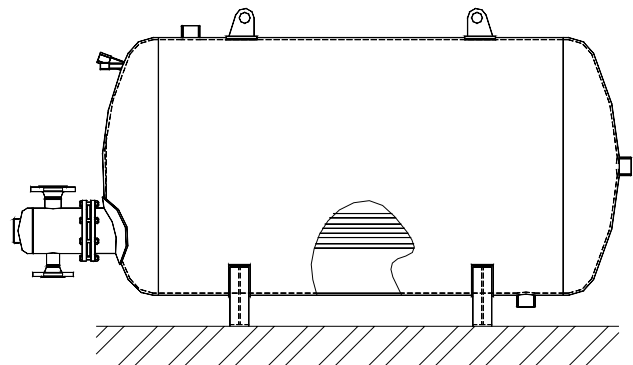

Horizontal vessel

**HEATING COILS FAX INQUIRY**

Please send the inquiry for your *AdcaTherm* steam to water heating coil (for existing vessels) with the following parameters:

STORAGE HOT WATER VESSELS – CLOSED TYPE			
	TUBE SIDE		VESSEL SIDE
FLUID	SATURATED STEAM		WATER
OPERATING PRESSURE	bar		bar
INITIAL TEMPERATURE	-----		° C
FINAL TEMPERATURE	-----		° C
VESSEL CAPACITY	-----		Kg or m3
RECOVERY PERIOD (In minutes)			
HEAT EXCHANGED (Option)	KW or		Kcal/h
VESSEL TYPE (Please select)	HORIZONTAL		VERTICAL
AVAILABLE DIMENSIONS (Send a sketch)	Straight length	mm	Diameter mm

Remarks : A coil in a cylindrical vertical vessel should be as close to but not exceeding the diameter of the vessel as possible. A coil in a horizontal vessel is typically approximately 2/3 the length of the vessel

SEMI – INSTANTANEOUS HOT WATER HEATER

If the vessel is also operating as semi-instantaneous hot water heater, please confirm :

HOT WATER CONSUMPTION	m3
INCOMING COLD WATER TEMPERATURE	° C
DESIRED HOT WATER TEMPERATURE	° C
LENGTH OF TIME (IN MINUTES)	

INSTANTANEOUS HOT WATER HEATER

If the vessel is also operating as instantaneous hot water heater, please confirm:

HOT WATER CONSUMPTION	m3/h
INCOMING COLD WATER TEMPERATURE	° C
DESIRED HOT WATER TEMPERATURE	° C

Remarks: If the instantaneous hot water consumption is greater than three times the storage capacity of the vessel, then the heating coil may be baffled to allow for an integral pump to force circulate water over the heating coil. We may also recommend the vessel capacity. In this case please supply all the consumption details such as quantity of water and temperatures.

Your company name:	
Contact :	
Address :	
Country :	
Tel.:	Fax.:
E-mail:	Web-page: