



# INSTALLATION AND MAINTENANCE INSTRUCTIONS

## FLT17

### FLOAT & THERMOSTATIC STEAM TRAPS

**GENERAL**

1. These instructions must be carefully read before any work involving products supplied by VALSTEAM ADCA ENGINEERING S.A. is undertaken.
2. The installation procedure is a critical stage in a life of a steam trap and care should be taken to avoid damage to the trap or equipment.

**Warning !**

- At start up , the presence of small particles in the water (dirt, scale, weld splatters, etc) may cause an unperfect closure of the seat . If this occur, proceed to an accurate cleaning.
- Do not touch the equipment without appropriate protection during working operation because it may conduct heat if the used fluid is at high temperature.
- Before starting maintenance be sure that the equipment is not pressurized or hot .
- The equipments must be used within the working temperature and pressure limits laid down for them, otherwise they may fail ( refer to nameplate and/or IS- Information Sheet).
- Do not remove the nameplate attached to the equipment. Serial number and other useful information is stamped on it.

**INSTALLATION**

1. Before to install remove plastic covers placed on flanges or connection ends. The equipment has an arrow or Inlet/Outlet designations. Be sure that it will be installed on the appropriate direction.
2. Install the steam trap in the point of the system, where the condensate tends to collect. It must be installed with the float lever in horizontal plane, so that it rises and falls vertically. An ADCA strainer should be installed upstream of the trap.

**Limiting conditions FLT 17 :**

PMA :Max.allowable pressure	16 bar
TMA: Max.allowable temperature	250 °C
PMO: Max.operating pressure	14 bar
TMO: Max.operating temperature	198 °C

**Max.differential pressure :**

- FLT 17-4.5 - 4.5 bar
- FLT 17 -10 - 10 bar
- FLT 17- 14 - 14 bar

**MAINTENANCE**

1. We recommend that the float steam traps are serviced as necessary. Steam traps should be checked periodically (at least yearly), to verify that they are operating correctly and to clean the internal parts and screen (if any).
2. When reassembling make sure that all gasket faces are clean and always use a new gasket. Tighten cover bolts uniformly in a diagonal sequence.
3. For further information refer to the relevant FLT17 brochure or consult our Sales Office.

**CE Marking :**

This product have been designed for use on steam and water wich are in Group 2 of the PED-European Pressure Equipment Directive 97/23/EC and it comply with those requirements.  
The product fall within category SEP and must not be CE marked.

## GROUP 2 GASES CATEGORIES

MODEL	SIZES	Category
FLT 17	ALL	SEP
FLT17HC	DN 25	SEP

**LOSS OF GUARANTEE : Total or partial disregard of above instructions involves loss of any right to guarantee.**



AR45

**PARTS LIST FOR FLT 17- STEAM TRAPS DN 1/2"- 1", DN15-DN25**

Code	Designation	SizeTrap	Pos.Nr.	Qty.
A.92.1502.015	Valve,seat,float&gasket D.P.4,5bar	DN1/2"-1"	3,4,5,6,7	1Set
A.92.1503.015	Valve,seat,float&gasket D.P.10 bar	DN1/2"-1"	3,4,5,6,7	1Set
A.92.1504.015	Valve,seat,float&gasket D.P.14 bar	DN1/2"-1"	3,4,5,6,7	1Set
A.92.1502.115	Float & gasket	DN1/2"-1"	3,7	1Set
A.92.1502.215	Air vent & gasket	DN1/2"-1"	3,8	1Set

**Recommended tightening torques FLT17 DN 1/2"-1", DN15-DN25**

Pos.Nr.	Size	Nm
4	1/2"-1"	50-55
8	1/2"-1"	50-55
9	1/2"-1"	40-45

Remarks: Tighten cover bolts uniformly.

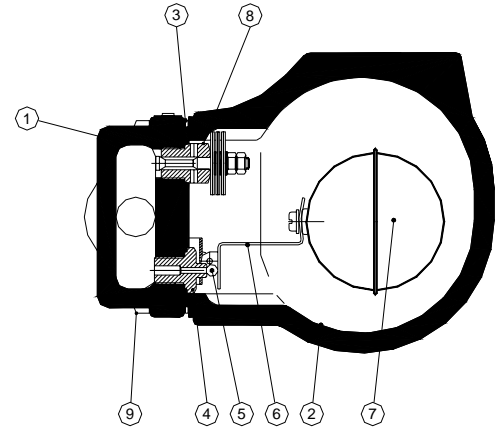

**PARTS LIST FOR FLT 17HC STEAM TRAPS DN 1", DN25**

Code	Designation	SizeTrap	Pos.Nr.	Qty.
A.92.1502.025	Valve,seat,float&gasket D.P.4,5bar	DN1"	3,4,5,6,7	1Set
A.92.1503.025	Valve,seat,float&gasket D.P.10 bar	DN1"	3,4,5,6,7	1Set
A.92.1504.025	Valve,seat,float&gasket D.P.14 bar	DN1"	3,4,5,6,7	1Set
A.92.1502.125	Float & gasket	DN1"	3,7	1Set
A.92.1502.225	Air vent& gasket	DN1"	3,8	1Set

**Recommended tightening torques FLT17HC DN 1", DN25**

Pos.Nr.	Size	Nm
4	1"	50-55
8	1"	50-55
9	1"	40-45

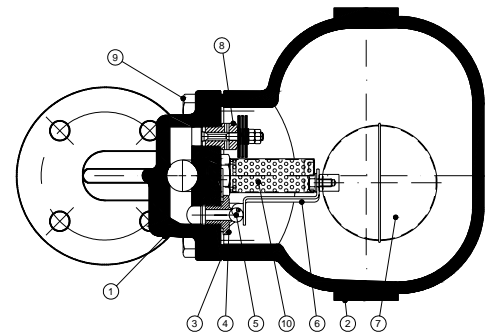
Remarks: Tighten cover bolts uniformly.

**PARTS LIST FOR FLT 17 STEAM TRAPS DN DN40-DN50**

Code	Designation	SizeTrap	Pos.Nr.	Qty.
A.92.1502.040	Valve,seat,float&gasket D.P.4,5bar	DN11/2"-2"	3,4,5,6,7	1Set
A.92.1503.040	Valve,seat,float&gasket D.P.10 bar	DN11/2"-2"	3,4,5,6,7	1Set
A.92.1504.040	Valve,seat,float&gasket D.P.14 bar	DN11/2"-2"	3,4,5,6,7	1Set
A.92.1502.140	Float & gasket	DN11/2"-2"	3,7	1Set
A.92.1502.240	Air vent& gasket	DN11/2"-2"	3,8	1Set

**Recommended tightening torques FLT17 DN40-DN50**

Pos.Nr.	Size	Nm
4	11/2"-2"	10-15 (4xM6)
8	11/2"-2"	50-55
9	11/2"-2"	80-85

Remarks: Tighten cover bolts uniformly.

