



INSTALLATION AND MAINTENANCE INSTRUCTIONS

BM - BIMETALIC STEAM TRAPS

BM 80 – BM 140

GENERAL

1. These instructions must be carefully read before any work involving products supplied by VALSTEAM ADCA ENGINEERING S.A. is undertaken.
2. The installation procedure is a critical stage in a life of a steam trap and care should be taken to avoid damage to the trap or equipment.

Warning!

- At start up, the presence of small particles in the water (dirt, scale, weld splatters, etc) may cause an unperfected closure of the seat. If this occurs, proceed to an accurate cleaning.
- Do not touch the equipment without appropriate protection during working operation because it may conduct heat if the used fluid is at high temperature.
- Before starting maintenance be sure that the equipment is not pressurized or hot.
- The equipments must be used within the working temperature and pressure limits laid down for them, otherwise they may fail (refer to nameplate and/or IS- Information Sheet).
- Do not remove the nameplate attached to the equipment. Serial number and other useful information is stamped on it.

INSTALLATION

1. Before to install remove plastic covers placed on flanges or connection ends. The equipment has an arrow or Inlet/Outlet designations. Be sure that it will be installed on the appropriate direction.
2. Install the steam trap in the point of the system, where the condensate tends to collect. It can be installed in any position. An ADCA strainer can be installed upstream of the trap as additional protection.

LIMITING CONDITIONS	BM80	BM140
PMA: Max. allowable pressure	100	160
TMA: Max. allowable temperature	450°C	550°C
PMO: Max. operating pressure	80 bar	140 bar
TMO: Max. operating temperature	450°C	550°C

MAINTENANCE

1. We recommend that the steam traps are serviced as necessary. Steam traps should be checked periodically (at least yearly), to verify that they are operating correctly and to clean the internal parts and strainer screen.
2. When reassembling make sure that all gasket faces are clean and always use a new gasket. Tighten cover bolts uniformly in a diagonal sequence.
3. For further information refer to the relevant IS (Information Sheet) or consult our Sales Office.

CE Marking :

This product have been designed for use on steam and water which are in Group 2 of the PED- European Pressure Equipment Directive 97/23/EC and it comply with those requirements. The product fall within category SEP and must not be CE marked.

PARTS LIST FOR BM 80:

CODE	DESIGNATION	TRAP SIZE DN	POS.NR.	QTY.
A.95.5150.015	Valve regulator & gasket	½" - 1"	3, 4,6	1 set
A.95.5150.115	Strainer screen & gasket	½" - 1"	3,5	1 set

Recommended tightening torques:

POS.NR.	TRAP SIZE DN	Nm
7	½" - 1"	120

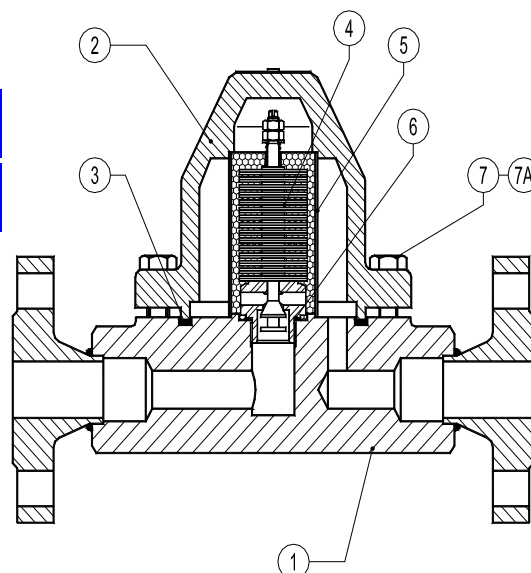

PARTS LIST FOR BM 140:

CODE	DESIGNATION	TRAP SIZE DN	POS.NR.	QTY.
A.95.5151.015	Valve regulator & gasket	½" - 1"	3, 4,6	1 set
A.95.5151.115	Strainer screen & gasket	½" - 1"	3,5	1 set

Recommended tightening torques:

POS.NR.	TRAP SIZE DN	Nm
7	½" - 1"	160

LOSS OF GUARANTEE: Total or partial disregard of above instructions involves loss of any right to guarantee.