



## INSTALLATION AND MAINTENANCE INSTRUCTIONS FA 20 COMPRESSED AIR TRAP

### GENERAL

1. These instructions must be carefully read before any work involving products supplied by VALSTEAM ADCA ENGINEERING S.A. is undertaken.
2. The installation procedure is a critical stage in a life of compressed air trap and care should be taken to avoid damage to the trap or equipment.

### **Warning !**

- At start up , the presence of small particles in the water (dirt,scale,weld splatters,etc) may cause an unperfect closure of the seat . If this occur, proceed to an accurate cleaning.
- Do not touch the equipment without appropriate protection during working operation because it may conduct heat if the used fluid is at high temperature.
- Before starting maintenance be sure that the equipment is not pressurized or hot .
- The equipments must be used within the working temperature and pressure limits laid down for them, otherwise they may fail ( refer to nameplate and/or IS- Information Sheet).
- Do not remove the nameplate attached to the equipment. Serial number and other useful information is stamped on it.

### INSTALLATION

1. Before to install remove plastic covers placed on flanges or connection ends. The equipment has an arrow or Inlet/Outlet designations. Be sure that it will be installed on the appropriate direction.
2. Install the compressed air trap in the point of the system, where the condensate tends to collect. It must be installed with the float lever in horizontal plane, so that it rises and falls vertically. A drip pipe is recommended to discharge to a safe place.

### Limiting conditions :

PMA:Max.allowable pressure	40 bar
TMA:Max.allowable temperature	400 °C
PMO:Max.operating pressure	32 bar
TMO:Max.operating temperature	200 °C

### Application limits :

Max.differential pressure:	
FA 20-21 - Max.differential pressure	21 bar

### MAINTENANCE

1. We recommend that the compressed air traps are serviced as necessary. Compressed air traps should be checked periodically(at least yearly), to verify that they are operating correctly and to clean the internal screen(if any).
2. When reassembling make sure that all gasket faces are clean and always use a new gasket. Tighten cover bolts uniformly in a diagonal sequence.
3. For further information refer to the relevant FA20 brochure or consult our Sales Office.

### CE Marking :

This product have been designed for use on steam and water wich are in Group 2 of the PED-European Pressure Equipment Directive 97/23/EC and it comply with those requirements.  
The product fall within category SEP and must not be CE marked.

**PARTS LIST FOR FA 20-21 COMPRESSED AIR TRAPS :**

Code	Designation	SizeTrap	Pos.Nr.	Qty.
A.95.3105.015	Valve,seat,float&gasket	DN1/2"-1"	3,4,5,6	1Set
A.95.3105.115	Float & gasket	DN1/2"-1"	3,7	1Set

**Recommended tightening torques FA20-21:**

Pos.Nr.	Size	Nm
4	1/2"-1"	40-45
9	1/2"-1"	50-55

Remarks: Tighten cover bolts uniformly.

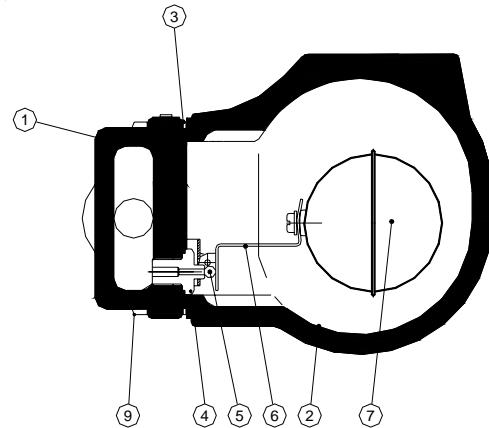

**TYPICAL INSTALLATION**

