

# INSTALLATION AND MAINTENANCE INSTRUCTIONS

## PNEUMATIC CONTROL VALVE

### ADCATROL PV16 – PV25 – PV40

#### GENERAL

1. These instructions must be carefully read before any work involving products supplied by VALSTEAM ADCA ENGINEERING S.A. is undertaken.
2. The installation procedure is a critical stage in a life of a valve and care should be taken to avoid damage to the valve or equipment.  
Control valves are designed to give accurate control . They give their maximum performance only when the equipment and piping associated with them is correctly sized and installed in accordance with our recommendations.
3. Referring to the name-plate located on pneumatic actuator yoke, check that the product is suitable for the intended use/application as follows:
  - body material must be compatible with the process fluid
  - compatibility with pressure and temperature and their maximum and minimum values
4. Adcatrol control valves are not intended to withstand external stresses that may be induced by any system to which they are fitted. It is the responsibility of the installer to consider these stresses and take adequate precautions to minimise them.

#### **Warning!**

- At start up, the presence of small particles in the fluid (dirt, scale, weld splatters, etc) may cause an unperfected closure of the seat. If this occurs, proceed to an accurate cleaning.
- Do not touch the equipment without appropriate protection during working operation because it may conduct heat if the used fluid is at high temperature.
- Before starting maintenance be sure that the equipment is not pressurized or hot. Even if upstream and downstream isolating valves have been closed care should be taken since fluid under pressure may be trapped between them.
- The equipments must be used within the working temperature and pressure limits laid down for them, otherwise they may fail (refer to nameplate and/or IS- Information Sheet).
- All work must be carried out or be supervised by a suitably competent person.
- Manual handling of products may present a risk of injury. You are advised to assess the risks taking into account the task, the individual, the load and the working environment.
- Before starting work ensure that you have suitable tools and/or consumables available. Use only genuine ADCA replacement parts.
- Do not remove the nameplate attached to the equipment. Serial number and other useful information is stamped on it.

## INSTALLATION

1. Before to install remove plastic covers placed on flanges or connection ends. The equipment has an arrow or Inlet/Outlet designations. Be sure that it will be installed on the appropriate direction.
2. Take care with jointing material to ensure that none may be permitted to block or enter the valve.
3. Control valves are recommended to be fitted with the centre line of the valve in a vertical position to ensure that the best results are obtained.
4. An ADCA pipeline strainer should be installed upstream of the valve to protect from dirt which could damage the valve or cause mal-functioning.
5. The control valve pipe work should be properly supported and free from strain and it should not be subjected to undue surges of pressure.  
For steam installations we strongly recommend that the control valve is positioned where condensation is unable to collect or that, alternatively, separators and steam traps are fitted so that the pipe work drains correctly. The start up condition should be considered.
6. If the system can not be stopped for maintenance it is recommended that isolating valves are installed upstream and downstream of the control valve together with a by-pass manual regulating valve. The process can be then controlled manually during the control valve maintenance.
7. A safety device should be included in the system to prevent dangerous overpressure or over temperature occurrence, if applicable.
8. The pneumatic actuator is provided of two 1/4"NPT connections, one of these has a silencer. Connect the air to the free 1/4" connection. The inlet air must be dry, oil and water free and its pressure would not exceed 3,5 bar (50 psi). The suitable control signal is displayed on the name-plate fixed on the valve yoke. If the valve is provided of positioner see also the Installation and Maintenance Instruction IMI PE986.10 and IMI PP981.10.
9. Control valves can be supplied with different kind of actuators, positioners, converters, etc. All these components have different limiting conditions which are specified on the nameplates and catalogues and they must be respected. Positioners, electric actuators and other equipment have their own installation instructions.

## PERIODICAL CHECKING

24 hours after the start up, it is recommended to check pipe connections and verify the tightening of flanges locknuts. Graphite packing should be compressed by tightening the threaded bushing (3) (see fig.7) about a ¼ of a turn (care should be taken since overtightening may lock-up the valve stem).

## MAINTENANCE

1. We recommend that the control valves to be serviced as necessary. Control valves should be checked periodically (at least yearly), to verify that they are operating correctly.
2. When reassembling, make sure that all gasket faces are clean and always use a new gasket. Tighten cover bolts uniformly in a diagonal sequence.
3. For further information refer to the relevant IS brochure or consult the factory or distributor.

## REPLACEMENT OF ACTUATOR DIAPHRAGM

In reference to the fig.1 and 2 proceed as follow:

- Remove the housing screws (14) except the long ones (15) which must be gradually loosen only when the other bolts have been already removed.
- Remove the housing lid (1) by loosening the plate locknut (13) and removing the disc plate (12) then replace the diaphragm (11).
- Refit all the items in reverse order.

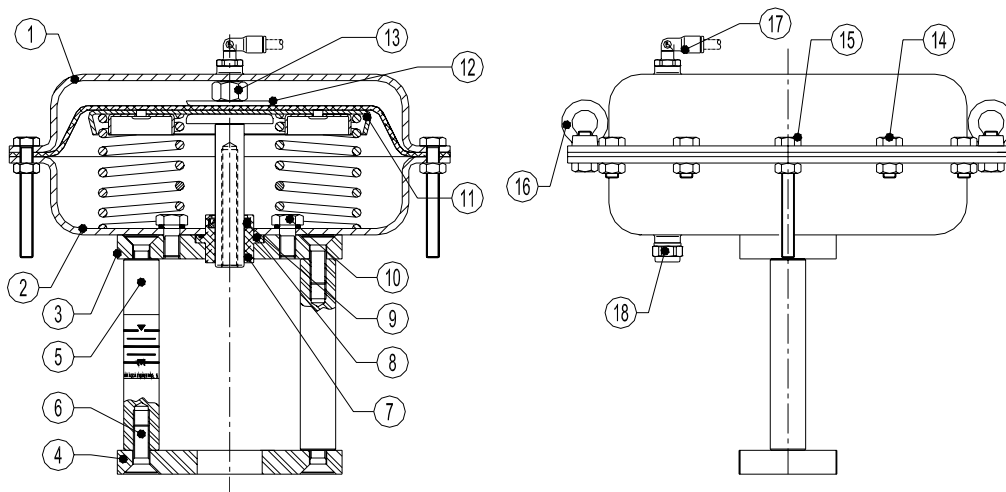

Fig.1 – Direct action actuator

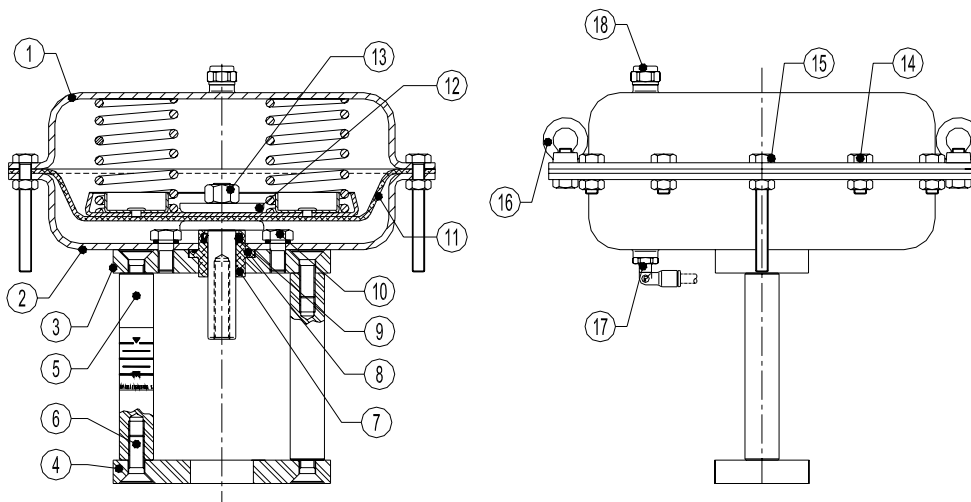

Fig.2 – Reverse action actuator

### REMOVING ACTUATOR FROM VALVE

In reference to the fig.3 proceed as follow:

- Loosen the lock nuts (4).
- Release air supply to the actuator and drive it into approximately mid-travel position.
- Loosen the mounting nut (2) completely.
- Reduce air supply pressure until housing is pressure free.
- Check and measure the shifting between yoke base plate (6) and flange valve body (5) and take note .
- Catch the actuator pillars and remove it from valve body . Nuts (4) can be used to fix the valve spindle in order to avoid it's rotation and consequently valve plug damage against the seat. Valve spindles are burnished and if this super finishing is destroyed doing to the use of wrong tools packing will be consequently damage in a short period of time.
- Re-assemble all the items in reverse order ensuring the alignment of spindles and plug-seat consequently.

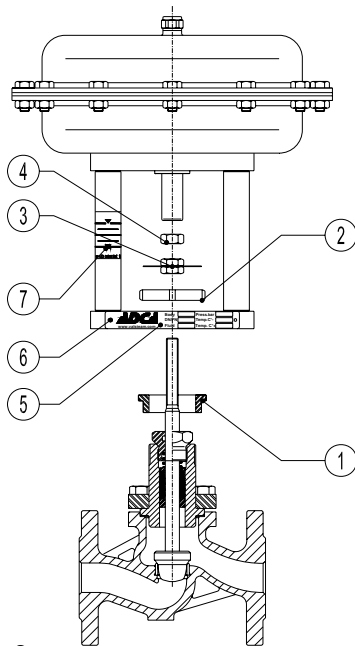

Fig.3

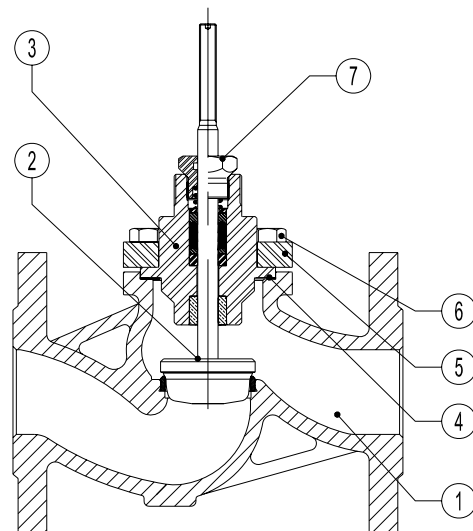

Fig.4

## REPLACING STANDARD PLUG

Separate the actuator from the valve body as described before. In reference to fig.14 proceed as follow:

- Loosen the threaded bushing (7) and screw off the lock nuts (6).
- Remove the bonnet (3) from the valve body (1)
- Take off the complete plug stem (2) from the bonnet (3).
- Apply silicon oil on the new complete plug stem and introduce it into the bonnet (3).
- Replace the body gasket (4) after cleaning its housing face carefully.
- Re-assemble all the items in reverse order ensuring the alignment of spindles and plug-seat consequently.

**Caution:** always change the old packing gland when the plug stem replacing is occurred

## REPLACING PACKINGS

Take off the complete plug stem as described on paragraph “REPLACING STANDARD PLUG”, then, in reference to the Fig.5,6 and 7 proceed as follow:

- Screw off the threaded bushing (3).
- Remove spring (4) and packing (graphite type G packing do not have spring).
- Clean the packing chamber accurately and apply silicon oil to the individual parts of the new packing and the plug stem.
- Insert the plug stem in the valve bonnet (see note).
- Lodge the new packing and its spring following the right sequence.
- Replace the body gasket (4) (see fig. 4) after cleaning its housing face carefully.
- Re-assemble all the items ensuring the alignment of spindles and plug-seat consequently.

**Note:** The valve stem should be correctly fitted within the bonnet before replacing the packing in order to avoid v-rings damage.

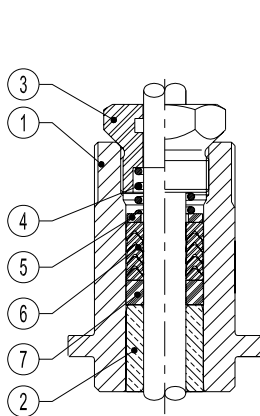

Fig. 5 – Packing type V

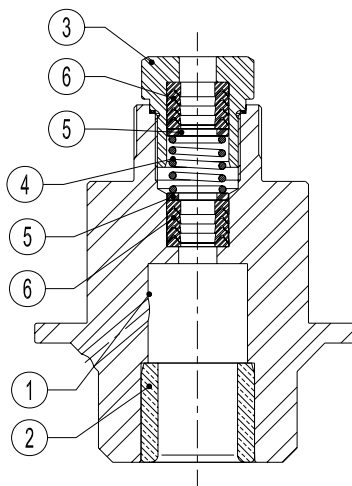

Fig. 6 – Packing type VV

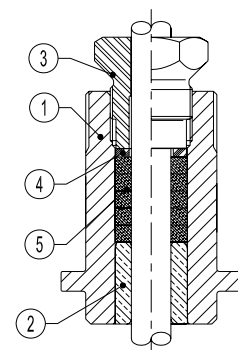
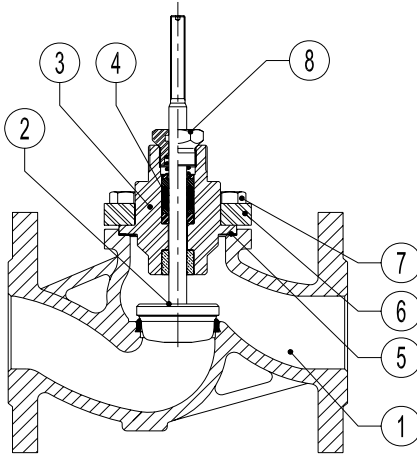
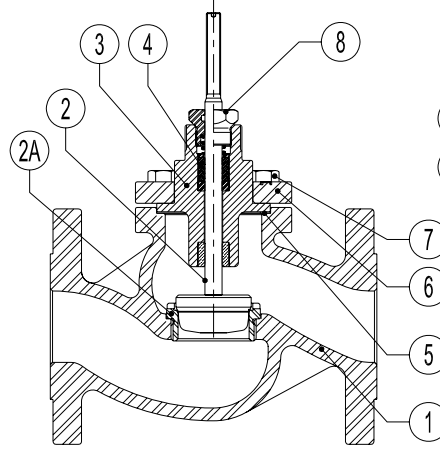
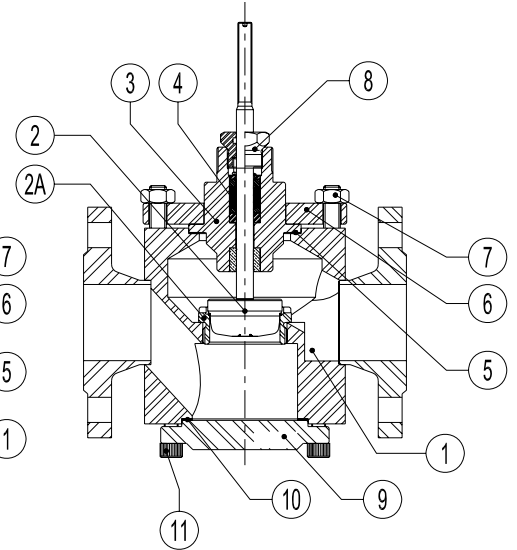

Fig. 7 – Packing type G

**Safety note:** care should be taken when handling the gaskets. Some gaskets are stainless steel reinforced and can easily cut.

**PARTS LIST FOR V SERIES CONTROL VALVES:**

**Fig. 9 – PV16**

**Fig. 10 – PV25**

**Fig. 11 – PV40**

<b>V16 TWO WAY VALVE</b>				
<b>CODE</b>	<b>DESIGNATION</b>	<b>VALVE SIZE DN</b>	<b>POS.NR.</b>	<b>QTY.</b>
9.PV16P.0015	Plug with soft seal and gasket	15	2,5	1 set
9.PV16P.0020	Plug with soft seal and gasket	20	2,5	1 set
9.PV16P.0025	Plug with soft seal and gasket	25	2,5	1 set
9.PV16P.0032	Plug with soft seal and gasket	32	2,5	1 set
9.PV16P.0040	Plug with soft seal and gasket	40	2,5	1 set
9.PV16P.0050	Plug with soft seal and gasket	50	2,5	1 set
9.PV16P.0065	Plug with soft seal and gasket	65	2,5	1 set
9.PV16P.0080	Plug with soft seal and gasket	80	2,5	1 set
9.PV16P.0100	Plug with soft seal and gasket	100	2,5	1 set
9.PV16.V11	V-Type packing rings	15-50	4,5	1 set
9.PV16.VV11	V-Type packing rings	65-100	4,5	1 set
9.PV16.G1	Graphite packing	15-100	4,5	1 set
9.PV16.0015	Body gasket	15-20	5	1
9.PV16.0025	Body gasket	25-32	5	1
9.PV16.0040	Body gasket	40-50	5	1
9.PV16.0065	Body gasket	65-80	5	1
9.PV16.0100	Body gasket	100	5	1

<b>V25 TWO WAY VALVE</b>				
<b>CODE</b>	<b>DESIGNATION</b>	<b>VALVE SIZE DN</b>	<b>POS.NR.</b>	<b>QTY.</b>
9.PV25P.0015	Plug with soft seal and gasket	15	2,5	1 set
9.PV25P.0020	Plug with soft seal and gasket	20	2,5	1 set
9.PV25P.0025	Plug with soft seal and gasket	25	2,5	1 set
9.PV25P.0032	Plug with soft seal and gasket	32	2,5	1 set
9.PV25P.0040	Plug with soft seal and gasket	40	2,5	1 set
9.PV25P.0050	Plug with soft seal and gasket	50	2,5	1 set
9.PV25P.0065	Plug with soft seal and gasket	65	2,5	1 set
9.PV25P.0080	Plug with soft seal and gasket	80	2,5	1 set
9.PV25P.0100	Plug with soft seal and gasket	100	2,5	1 set
9.PV25P.1015	Metal plug and gasket	15	2,5	1 set
9.PV25P.1020	Metal plug and gasket	20	2,5	1 set
9.PV25P.1025	Metal plug and gasket	25	2,5	1 set
9.PV25P.1032	Metal plug and gasket	32	2,5	1 set
9.PV25P.1040	Metal plug and gasket	40	2,5	1 set
9.PV25P.1050	Metal plug and gasket	50	2,5	1 set
9.PV25P.1065	Metal plug and gasket	65	2,5	1 set
9.PV25P.1080	Metal plug and gasket	80	2,5	1 set
9.PV25P.1100	Metal plug and gasket	100	2,5	1 set
9.PV25S.0015	Standard valve seat	15	2,5	1 set
9.PV25S.0020	Standard valve seat	20	2,5	1 set
9.PV25S.0025	Standard valve seat	25	2,5	1 set
9.PV25S.0032	Standard valve seat	32	2,5	1 set
9.PV25S.0040	Standard valve seat	40	2,5	1 set
9.PV25S.0050	Standard valve seat	50	2,5	1 set
9.PV25S.0065	Standard valve seat	65	2,5	1 set
9.PV25S.0080	Standard valve seat	80	2,5	1 set
9.PV25S.0100	Standard valve seat	100	2,5	1 set
9.PV25.V11	V-Type packing rings	15-50	4	1 set
9.PV25.VV11	V-Type packing rings	65-100	4	1 set
9.PV25.G1	Graphite packing	15-100	4	1 set
9.PV25.0015	Body gasket	15-25	5	1
9.PV25.0025	Body gasket	32-50	5	1
9.PV25.0040	Body gasket	65-80	5	1
9.PV25.0065	Body gasket	100	5	1

<b>V40 TWO WAY VALVE</b>				
<b>CODE</b>	<b>DESIGNATION</b>	<b>VALVE SIZE DN</b>	<b>POS.NR.</b>	<b>QTY.</b>
9.PV40P.0015	Plug with soft seal and gasket	15	2,5,10	1 set
9.PV40P.0020	Plug with soft seal and gasket	20	2,5,10	1set
9.PV40P.0025	Plug with soft seal and gasket	25	2,5,10	1set
9.PV40P.0032	Plug with soft seal and gasket	32	2,5,10	1set
9.PV40P.0040	Plug with soft seal and gasket	40	2,5,10	1set
9.PV40P.0050	Plug with soft seal and gasket	50	2,5,10	1set
9.PV40P.1015	Metal plug and gasket	15	2,5,10	1set
9.PV40P.1020	Metal plug and gasket	20	2,5,10	1set
9.PV40P.1025	Metal plug and gasket	25	2,5,10	1set
9.PV40P.1032	Metal plug and gasket	32	2,5,10	1set
9.PV40P.1040	Metal plug and gasket	40	2,5,10	1set
9.PV40P.1050	Metal plug and gasket	50	2,5,10	1set
9.PV40S.0015	Standard valve seat	15	2,5,10	1set
9.PV40S.0020	Standard valve seat	20	2,5,10	1set
9.PV40S.0025	Standard valve seat	25	2,5,10	1set
9.PV40S.0032	Standard valve seat	32	2,5,10	1set
9.PV40S.0040	Standard valve seat	40	2,5,10	1set
9.PV40S.0050	Standard valve seat	50	2,5,10	1set
9.PV40.V11	V-Type packing rings	15-50	4	1 set
9.PV40.G1	Graphite packing	15-50	4	1 set
9.PV40.0015	Body gasket	15-25	5,10	1
9.PV40.0025	Body gasket	32-50	5,10	1



**PARTS LIST FOR PA SERIES ACTUATORS :**

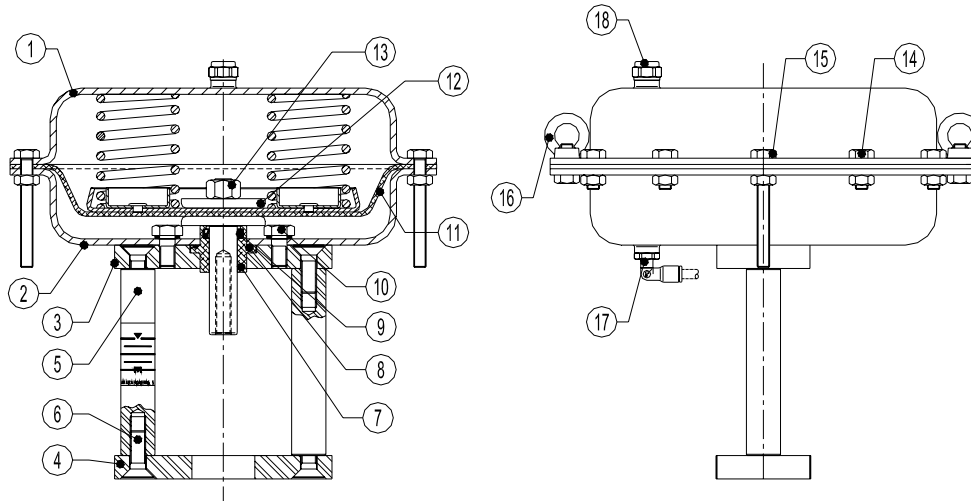

**Fig.8 – PA series actuator**

CODE	DESIGNATION	ACTUATOR TYPE	POS.NR.	QTY.
9.PA205.10	Actuator Diaphragm PA-205	PA205DA and RA	11	1
9.PA280.10	Actuator Diaphragm PA-280	PA280DA and RA	11	1
9.PA340.10	Actuator Diaphragm PA-340	PA340DA and RA	11	1
9.PA435.10	Actuator Diaphragm PA-435	PA435DA and RA	11	1
9.PA205.11	Set of diaphragm seals	PA205-PA435	8,9	1

**USEFUL NOTES ON VALVE AND PIPE SIZING**

Never size the valve according to the pipe diameter in which it has to be fitted but according to the required actual flow of steam or water. Refer to valve calculation data sheet or consult factory.

**TYPICAL INSTALLATION**

Please consult the available standard assembling drawings or consult the factory for a specific installation drawing.

**LOSS OF GUARANTEE:** Total or partial disregard of above instructions involves loss of any right to guarantee.