

INSTALLATION AND MAINTENANCE INSTRUCTIONS

“ADCATROL” INTERMITTENT BLOWDOWN VALVES

VPA26S

GENERAL

1. These instructions must be carefully read before any work involving products supplied by VALSTEAM ADCA ENGINEERING S.A. is undertaken.
2. The installation procedure is a critical stage in a life of a valve and care should be taken to avoid damage to the valve or equipment.
Control valves are designed to give accurate control . They give their maximum performance only when the equipment and piping associated with them is correctly sized and installed in accordance with our recommendations.
3. Referring to the name-plate located on pneumatic actuator yoke, check that the product is suitable for the intended use/application as follows:
 - body material must be compatible with the process fluid
 - compatibility with pressure and temperature and their maximum and minimum values
4. Adcatrol control valves are not intended to withstand external stresses that may be induced by any system to which they are fitted. It is the responsibility of the installer to consider these stresses and take adequate precautions to minimise them.

Warning!

- At start up or after boiler maintenance, the presence of metal particles in the fluid (weld splatters, etc) may cause an unperfected closure of the seat. If this occurs, proceed to an accurate cleaning.
- Do not touch the equipment without appropriate protection during working operation because it may conduct heat if the used fluid is at high temperature.
- Before starting maintenance be sure that the equipment is not pressurized or hot. Even if upstream and downstream isolating valves have been closed care should be taken since fluid under pressure may be trapped between them.
- The equipments must be used within the working temperature and pressure limits laid down for them, otherwise they may fail (refer to nameplate and/or IS- Information Sheet).
- All work must be carried out or be supervised by a suitably competent person.
- Manual handling of products may present a risk of injury. You are advised to assess the risks taking into account the task, the individual, the load and the working environment.
- Before starting work ensure that you have suitable tools and/or consumables available. Use only genuine ADCA replacement parts.
- Do not remove the nameplate attached to the equipment. Serial number and other useful information is stamped on it.

CE MARKING (PED - European Directive 97/23/EC)	
PN 25	Category
DN15 to DN40	SEP - art. 3, paragraph3
DN50	1 (CE Marked)

INSTALLATION

1. Before to install remove plastic covers placed on flanges or connection ends. The equipment has an arrow or Inlet/Outlet designations. Be sure that it will be installed on the appropriate direction.
2. Take care with jointing material to ensure that none may be permitted to block or enter the valve.
3. Control valves are recommended to be fitted with the centre line of the valve in a vertical position to ensure that the best results are obtained.
4. The control valve pipe work should be properly supported and free from strain and it should not be subjected to undue surges of pressure.
5. If the system can not be stopped for maintenance it is recommended that isolating valves are installed upstream of the blowdown valve.
6. A safety device (limit switch) should be requested with the valve to prevent the boiler drainage accidentally in case the valve does not close properly due for example to metal impurities retained between the valve plug and seat. This is particularly recommended if the boiler is running during the night and/or without boiler house operator.
7. The pneumatic actuator is provided of two 1/4"NPT connections, one of these has a silencer. Connect the air to the free 1/4" connection. The inlet air must be dry, oil and water free and it's pressure should not exceed 3,5 bar (50 psi). The suitable control signal is displayed on the name-plate fixed on the valve yoke. If the valve is provided of limit switch, timer, 3 way solenoid valve and air pressure regulator see also the Installation and the applicable Maintenance Instructions.
8. Blowdown valves can be supplied with different kind of actuators, limit switches, etc. All these components have different limiting conditions which are specified on the nameplates and catalogues and they must be respected, their own installation instructions must be consulted.

PERIODICAL CHECKING

24 hours after the start up, it is recommended to check pipe connections and verify the tightening of flanges locknuts. Graphite packing should be compressed by tightening the threaded bushing (3) (see fig.7) about a ¼ of a turn (care should be taken since over tighten may lock-up the valve stem).

MAINTENANCE

1. Before any maintenance service on a steam boiler, depressurise, drain and vent the boiler to atmosphere.
2. We recommend that the blowdown valves to be serviced as necessary. Blowdown valves should be checked periodically (at least yearly), to verify that they are operating correctly.
3. When reassembling, make sure that all gasket faces are clean and always use a new gasket. Tighten cover bolts uniformly in a diagonal sequence.
4. For further information refer to the relevant IS brochure or consult the factory or distributor.

REPLACEMENT OF ACTUATOR DIAPHRAGM

In reference to the fig.1 and 2 proceed as follow:

- Before to start confirm that the actuator was properly vented.
- Remove the housing screws (14) except the long ones (15) which must be gradually loosen only when the other bolts have been already removed (diaphragm housing contains springs under pressure).
- Remove the housing lid (1) by loosening the plate locknut (13) and removing the disc plate (12) then replace the diaphragm (11).
- Refit all the items in reverse order.

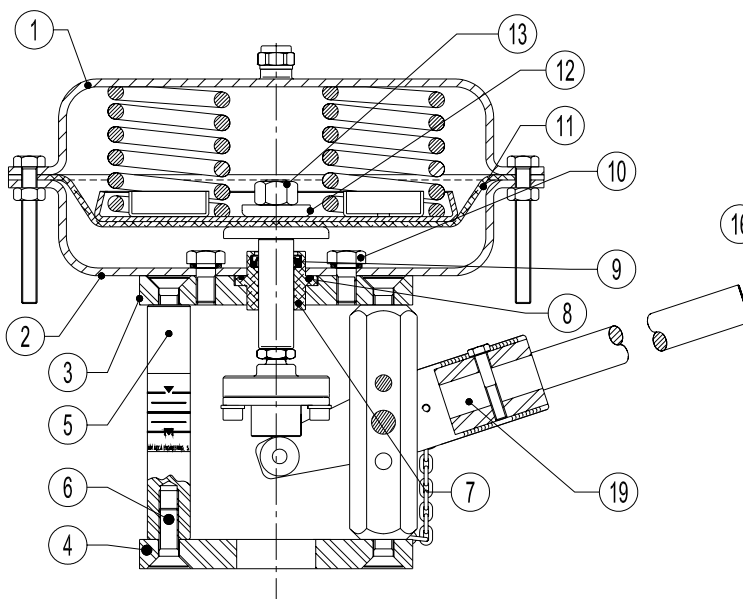

Fig.1 – Reverse action actuator

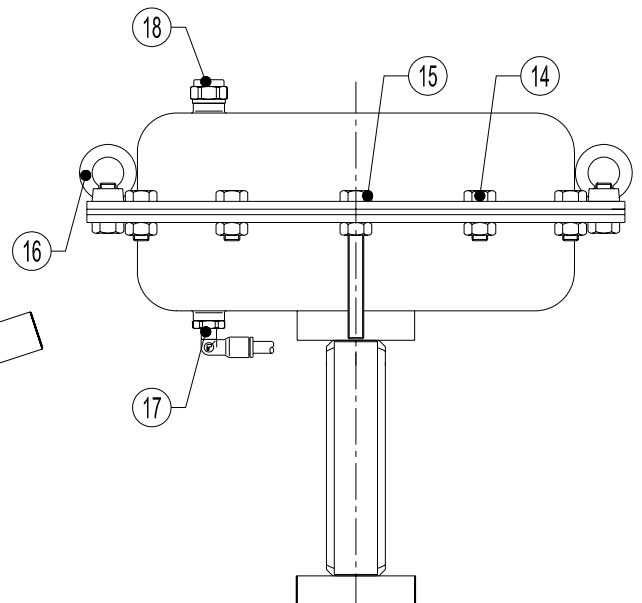

Fig. 2

REMOVING ACTUATOR FROM VALVE

In reference to the fig.3 proceed as follow:

- Loosen the lock nuts (3) and connector (4).
- Release air supply to the actuator and drive it into approximately mid-travel position.
- Loosen the mounting nut (2) completely.
- Reduce air supply pressure until housing is pressure free.
- Check and measure the shifting between yoke base plate (6) and flange valve body (5) and take note .
- Catch the actuator pillars and remove it from valve body . Nut (3) can be used to fix the valve spindle in order to avoid it's rotation and consequently valve plug damage against the seat. Valve spindles are burnished and if this super finishing is destroyed doing to the use of wrong tools packing will be consequently damage in a short period of time.
- Re-assemble all the items in reverse order ensuring the alignment of spindles and plug-seat consequently.

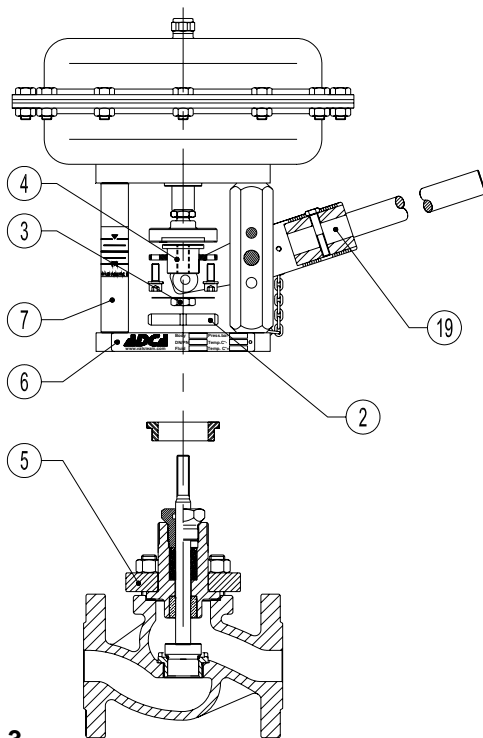

Fig. 3

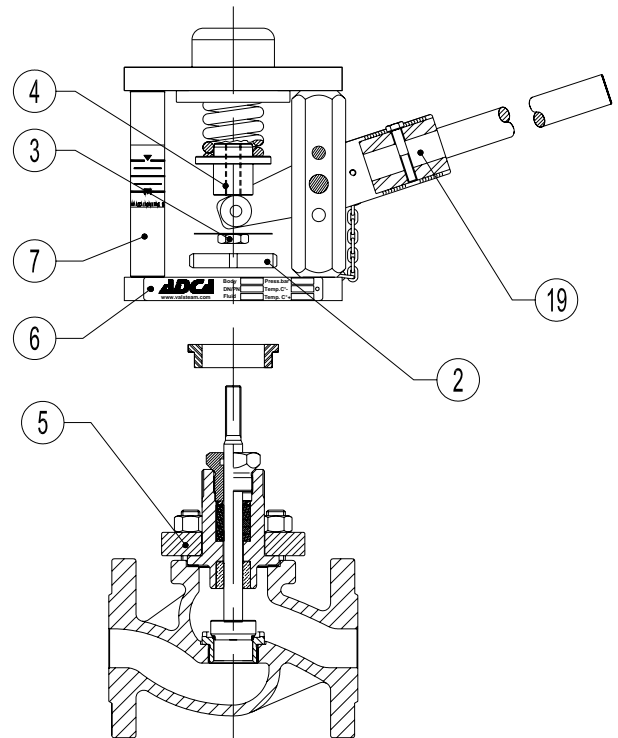

Fig. 4

REMOVING SPRING FROM MANUAL VALVE

In reference to the Fig.4 proceed as follows :

- Remove the lever (19)
- Loosen the mounting nut (2) completely
- Check and measure the shifting between yoke base plate (6) and flange valve body (5) and take note .
- Catch the actuator pillars and remove it from valve body . Nut (3) can be used to fix the valve spindle in order to avoid it's rotation and consequently valve plug damage against the seat. Valve spindles are burnished and if this super finishing is destroyed doing to the use of wrong tools packing will be consequently damage in a short period of time.
- Re-assemble all the items in reverse order ensuring the alignment of spindles and plug-seat consequently.

REPLACING STANDARD PLUG

Separate the actuator from the valve body as described before. In reference to fig.5 proceed as follow:

- Loosen the threaded bushing (7) and screw off the lock nuts (6).
- Remove the bonnet (3) from the valve body (1)
- Take off the complete plug stem (2) from the bonnet (3).
- Apply silicon oil on the new complete plug stem and introduce it into the bonnet (3).
- Replace the body gasket (4) after cleaning its housing face carefully.
- Re-assemble all the items in reverse order ensuring the alignment of spindles and plug-seat consequently.

Caution: always change the old packing gland when the plug stem replacing is occurred .

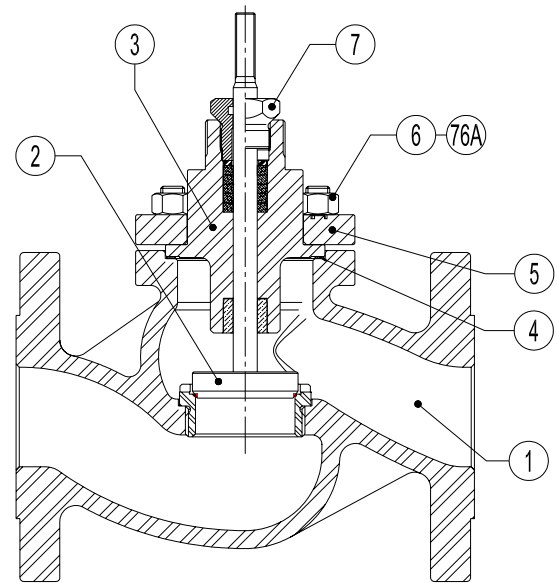

Fig. 5

REPLACING PACKINGS

Take off the complete plug stem as described on paragraph “REPLACING STANDARD PLUG”, then, in reference to the Fig. 6 proceed as follow:

- Screw off the threaded bushing (3).
- Remove the packing graphite set
- Clean the packing chamber accurately and apply silicon oil to the individual parts of the new packing and the plug stem.
- Insert the plug stem in the valve bonnet (see note).
- Lodge the new packing in the right sequence.
- Replace the body gasket (4) (see fig. 5) after cleaning its housing face carefully.
- Re-assemble all the items ensuring the alignment of spindles and plug-seat consequently.

Note: The valve stem should be correctly fitted within the bonnet before replacing the packing in order to avoid the packing damage.

Safety note: care should be taken when handling the gaskets. Some gaskets are stainless steel reinforced and can easily cut.

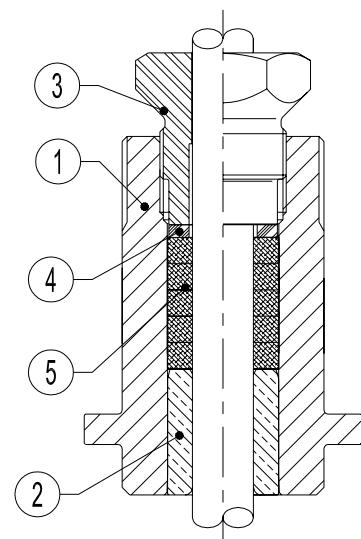

Fig. 6 – Packing type G

MANUAL OVERRIDE LEVER

In case of pneumatic actuated valves with manual override lever, it is recommended to remove the lever from the valve and store it in a safe place if not in use.

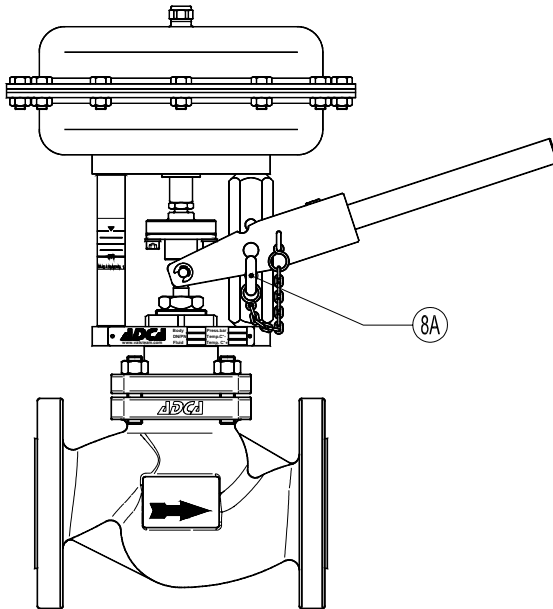

Fig. 7

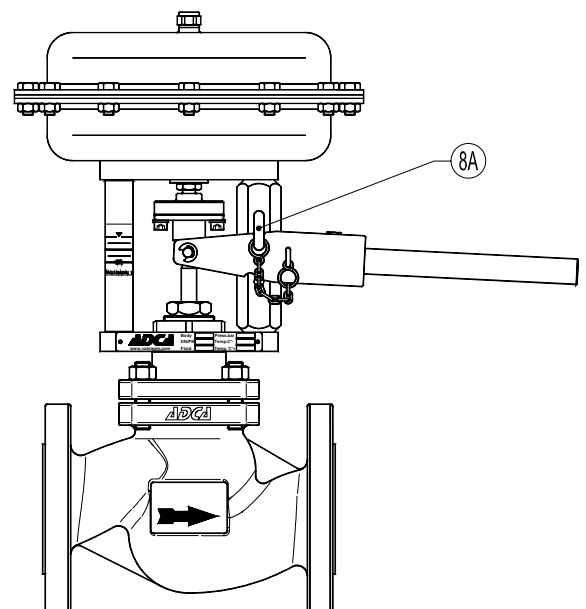
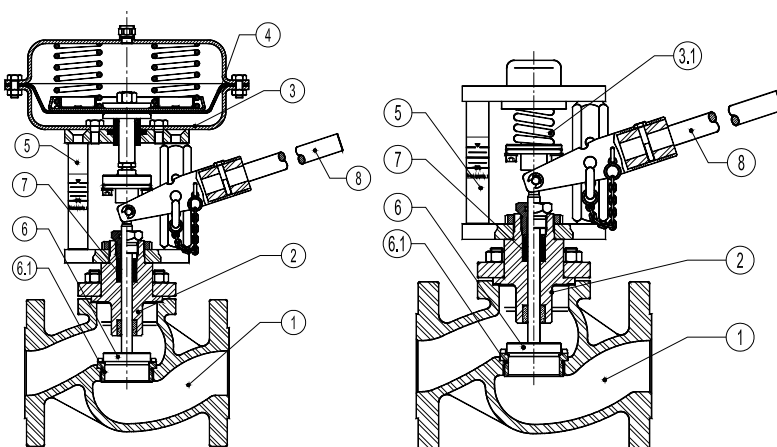

Fig. 8

Fig.7 Hand lever is locked. Valve opened by pneumatic or hydraulic actuator only.

Fig.8 The valve is locked in the open position by the locking pin nr. 8A.

PARTS LIST FOR VP26S BLOWDOWN VALVES



MATERIALS		
POS.	DESIGNATION	MATERIAL
1	Valve Body	A216 WCB (1.0619)
2	Bonnet	Stainless steel (1.4301)
3	* Actuator	Steel Fe410.1/St.Steel
3.1	* Spring	Spring Steel
4	* Diaphragm	NBR 70
5	Yoke	Carbon Steel/St.Steel
6	* Valve Plug	Hardened St. Steel
6.1	* Valve Seat	Hardened St. Steel
7	Packing	Graphite
8	Valve Lever	Stainless steel (1.4301)

* Available spare parts.

USEFUL NOTES ON VALVE AND PIPE SIZING

Never size the valve according to the pipe diameter in which it has to be fitted but according to the required actual flow of steam or water. Refer to valve calculation data sheet or consult factory.

TYPICAL INSTALLATION

Please consult the available standard assembling drawings or consult the factory for a specific installation drawing.

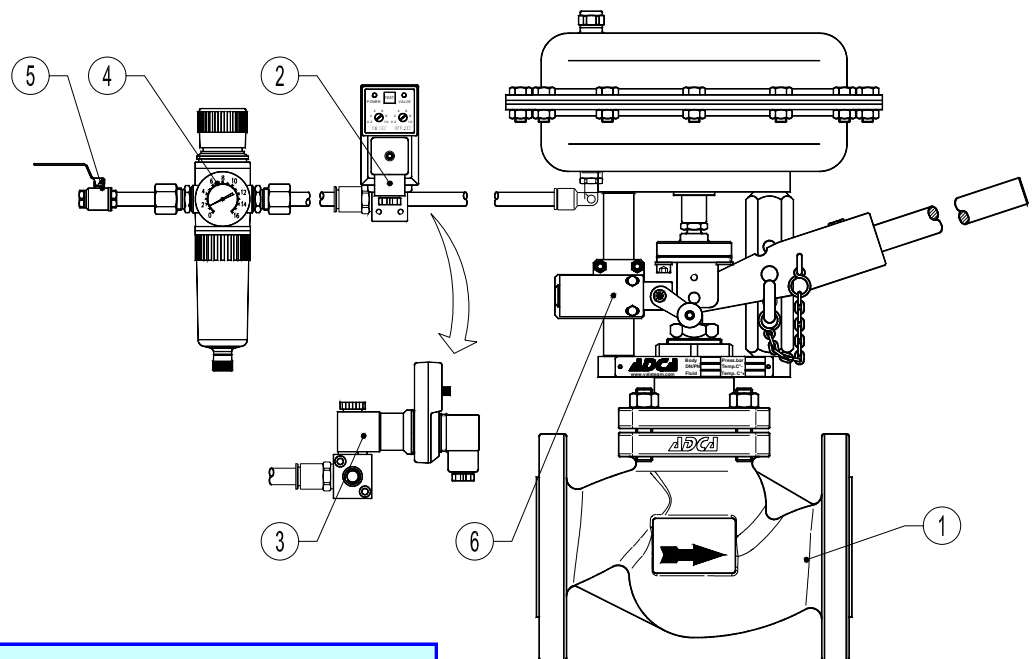

Position	Designation
1	VPA26S Blowdown Valve
2	ADCA Digital Timer plus Connector
3	ADCA Solenoid Valve 3/2
4	ADCA P10 Air Filter Regulator
5	Ball Valve
6	Limit Switch

LOSS OF GUARANTEE: Total or partial disregard of above instructions involves loss of any right to guarantee.